



HERITAGE HALTON HILLS COMMITTEE MERGED AGENDA

Date: Wednesday, November 20, 2024, 4:30 p.m.
Location: Esqueving Room - Halton Hills Town Hall
1 Halton Hills Drive
Members: Councillor C. Somerville, Chair, Councillor J. Racinsky, C. Donaldson, L. Quinlan, M. Rowe, R. Denny, A. Walker, T. Brown

1. CALL TO ORDER
2. DISCLOSURE OF PECUNIARY/CONFLICT OF INTEREST
3. *CLOSED SESSION*
Verbal Update by Recreation and Parks Staff regarding the security of the property of the municipality or local board. (Hornby)
4. RECEIPT OF PREVIOUS MINUTES
 - a. Minutes of the Heritage Halton Hills Committee Meeting held on October 16, 2024.
5. SCHEDULED ITEMS FOR DISCUSSION
 - a. Research and Evaluation report - 10295 10 Side Road - Stewart's Castle (Scotch Block)
 - b. Research and Evaluation Report - 12 and 14 Adamson Street North - Noble-Pomeroy House (Norval)
 - c. Research and Evaluation Report - 15 Mountain Street - Frances Williams House (Glen Williams)
 - d. Research and Evaluation Report - 8 Albert Street - Gibbons-Ross House (Georgetown)
 - e. 2025 Heritage Halton Hills Meeting Dates
6. ITEMS TO BE SCHEDULED FOR NEXT MEETING
7. ADJOURNMENT



**HERITAGE HALTON HILLS COMMITTEE
MINUTES**

Minutes of the Heritage Halton Hills Committee meeting held on Wednesday October, 16, 2024 in the Esqueing Room at Town Hall, 1 Halton Hills Drive, Halton Hills, ON.

Members Present: Councillor J. Racinsky, Acting Chair, C. Donaldson, L. Quinlan, R. Denny, T. Brown, Councillor C. Somerville, (arrived 4:56 pm)

Regrets: M. Rowe, A. Walker

Staff Present: L. Loney, Manager of Heritage Planning, L. Bateson, Senior Administrative & Heritage Planning Coordinator, A. Foster, Cultural Heritage Assistant, R. Brown, Deputy Clerk - Administration

Others Present: Councillor J. Brass

1. CALL TO ORDER

Councillor J. Racinsky, Acting Chair called the meeting to order at 4:33 p.m.

2. DISCLOSURE OF PECUNIARY/CONFLICT OF INTEREST

There were no disclosures of pecuniary or conflict of interest.

3. RECEIPT OF PREVIOUS MINUTES

Recommendation No. HHH-2024-0049

That the following minutes of the Heritage Halton Hills Committee Meetings be received:

- a. Heritage Halton Hills Committee Meeting Minutes dated August 14, 2024
- b. Heritage Halton Hills Committee Meeting Minutes dated September 18, 2024

CARRIED

4. SCHEDULED ITEMS FOR DISCUSSION

4.a Research and Evaluation Report - 2 Guelph Street (Georgetown) - R.D. Warren House

L. Loney provided an overview of the research and evaluation report. The property located at 2 Guelph Street (Georgetown) meets 4 out of the 9 criteria for designation. It is a representative example of Edwardian Classical architecture in the community of Georgetown. The property is associated with R.D. Warren, editor of the Georgetown Herald from 1886-1909, owner of the Halton Conservator, and McMaster University Senator. It serves to define and maintain the early twentieth century character of downtown Georgetown.

Recommendation No. HHH-2024-0050

THAT the Heritage Halton Hills Committee recommends Council issue a Notice of Intention to Designate for the property at 2 Guelph Street (Georgetown) for designation under the *Ontario Heritage Act*.

CARRIED

4.b Research and Evaluation Report - 2 Mill Street East (Acton) - Secord-Starkman Block

A. Foster provided an overview of the research and evaluation report. The property located at 2 Mill Street East (Acton) meets 6 out of the 9 criteria for designation. It is a representative example of early twentieth-century vernacular commercial architecture . The property is associated with Sara Augusta Secord and Abraham "Louis" Starkman. It is a local landmark in Acton and has significant contextual value.

Recommendation No. HHH-2024-0051

THAT the Heritage Halton Hills Committee recommends Council issue a Notice of Intention to Designate for the property at 2 Mill Street East (Acton) for designation under the *Ontario Heritage Act*.

CARRIED

4.c Research and Evaluation Report - 4 Queen Street (Georgetown) - McColl House

L. Loney provided an overview of the research and evaluation report. The property located at 4 Queen Street (Georgetown) meets 5 out of the 9 criteria for designation. It is a representative example of late-nineteenth-century residential buildings in the Gothic Revival style. The property is associated with John McColl and the development of Queen Street. It serves to define and maintain the late-nineteenth century character of the area surrounding the railway.

Recommendation No. HHH-2024-0052

THAT the Heritage Halton Hills Committee recommends Council issue a Notice of Intention to Designate for the property at 4 Queen Street (Georgetown) for designation under the *Ontario Heritage Act*.

CARRIED

4.d Research and Evaluation Report - 8 Queen Street (Georgetown) - Ramsden House

L. Loney provided an overview of the research and evaluation report. The property located at 8 Queen Street (Georgetown) meets 4 out of the 9 criteria for designation. It is a representative example of early 20th century Edwardian Classicism style residential building. The property is associated with the local pharmacy owner, George Alexander Ramsden. It has contextual value as it serves to define and maintain the early 20th century character of the area surrounding the railway.

Recommendation No. HHH-2024-0053

THAT the Heritage Halton Hills Committee recommends Council issue a Notice of Intention to Designate for the property at 8 Queen Street (Georgetown) for designation under the *Ontario Heritage Act*.

CARRIED

4.e Research and Evaluation Report - 526 Main Street (Glen Williams) - Beaumont Duplex

L. Loney provided an overview of the research and evaluation report. The property located at 526 Main Street (Glen Williams) meets 4 out of the 9 criteria for designation. It is a representative example of a late-Victorian residential duplex with Gothic Revival influences. The property has historical and associative value due to its associations with the Beaumont family and Glen Williams' late-nineteenth and early twentieth-century development.

Recommendation No. HHH-2024-0054

THAT the Heritage Halton Hills Committee recommends Council issue a Notice of Intention to Designate for the property at 526 Main Street (Glen Williams) for designation under the *Ontario Heritage Act*.

CARRIED

4.f Research and Evaluation Report - 7 Prince Street (Glen Williams) - Hawkins House

L. Loney provided an overview of the research and evaluation report. The property located at 7 Prince Street (Glen Williams) meets 7 out of the 9 criteria for designation. It is a representative example of a modest 3-bay Georgian Plan building. The property is associated with the Hawkins and Tost families. It defined the road layout by its placement, thereby making it a prominent landmark on Prince Street. It was the first brick house in Glen Williams.

Recommendation No. HHH-2024-0055

THAT the Heritage Halton Hills Committee recommends Council issue a Notice of Intention to Designate for the property at 7 Prince Street (Glen Williams) for designation under the *Ontario Heritage Act*.

CARRIED

4.g Research and Evaluation Report - 5 King Street (Georgetown) - Beamish-Applebe House

L. Loney provided an overview of the research and evaluation report. The property located at 5 King Street (Georgetown) meets 4 out of the 9 criteria for designation. It is a representative example of an early twentieth-century residential building in the Edwardian architectural style. The property is associated with cobbler Thomas and William Appelbe, C.O. of the Lorne Rifles for 40 years. It has significant contextual value.

Recommendation No. HHH-2024-0056

THAT the Heritage Halton Hills Committee recommends Council issue a Notice of Intention to Designate for the property at 5 King Street (Georgetown) for designation under the *Ontario Heritage Act*.

CARRIED

4.h Barnes Pioneer Cemetery Plaque

L. Loney advised the committee that M. Rowe had requested that there be a commemorative plaque placed at the Barnes Pioneer Cemetery location. L. Loney let the committee know that a plaque will be incorporated into the design of the space.

4.i Naming of Glen Bridges

Councillor J. Brass advised the committee that he and Councillor Racinsky would be bringing a motion to Council at the upcoming Council Meeting to request that the three bridges located in Glen Williams be named for local historical families rather than the generic numbers that they are currently recognized as.

Councillor Brass noted that the naming of the bridges is supported by the Esquesing Historical Society and the Glen Williams Community Association. A formal letter was sent by John Mark Rowe to Mayor Ann Lawlor dated October 9, 2024, supporting the naming of the bridges and the proposed names.

Councillor Brass stated the proposed bridge names are:

Bridge 1 – Forester

Bridge 2 – Williams

Bridge 3 - Inglis

Recommendation No. HHH-2024-0057

THAT the Heritage Halton Hills Committee endorse the naming of the bridges in Glen Williams in accordance with the letter from John Mark Rowe to Mayor Ann Lawlor, dated October 9, 2024

CARRIED

5. ITEMS TO BE SCHEDULED FOR NEXT MEETING

6. ADJOURNMENT

The meeting adjourned at 5:00 p.m.

Research and Evaluation Report



(Town of Halton Hills 2024)

Stewart's Castle
10295 10 Side Road, Scotch Block, Town of Halton Hills

October 2024

Project Personnel

Report Authors

Austin Foster, MA
Cultural Heritage Assistant

with

Laura Loney, MPlan, MCIP, CAHP, RPP
Manager of Heritage Planning

Historical Research

Austin Foster

Laura Loney

Field Review

Austin Foster

Laura Loney

Report Preparation

Austin Foster

Laura Loney

Mapping Graphics:

Rehan Waheed, MA
Planning Data Analyst

Report Reviewers:

Laura Loney

Caylee MacPherson
Planner – Development Review & Heritage

Bronwyn Parker
Director of Planning Policy

John Linhardt
Commissioner of Planning & Development

Table of Contents

1.0 Property Description 4

2.0 Background 4

 2.1 Historical Background 5

 2.2 Property & Architectural Description..... 12

 2.3 Architectural Style & Comparative Analysis 16

3.0 Description of Heritage Attributes and Evaluation Checklist 18

4.0 Summary 19

5.0 Sources 21

Table of Figures

Figure 1: Subject Property identified on Location Map 4

Figure 2: Subject Property identified in Aerial Photograph 4

Figure 3: Subject property identified in red on 1822 Patent Plan 6

Figure 4: Subject property identified on the 1858 *Tremaine's Map of the County of Halton, Canada West* 6

Figure 5: Mary Stewart identified as the owner of the subject property on the 1877 Halton County Atlas 8

Figure 6: Inauguration of natural gas in Georgetown (1956) (EHS p382f) 10

Figure 7: Richard “Dick” Howitt, c. 1970. (MHS 4534) 11

Figure 8: Richard “Dick” Howitt, c. 1985. (MHS 2779) 11

Figure 9: The subject property at 10295 10 Side Road c.1990s (EHS 18311). 11

Figure 10: The subject property at 10295 10 Side Road c.1990s (EHS 18312). 11

Figure 11: Aerial Photograph of 10295 10 Side Road (Town of Halton Hills, 2024) 12

Figure 12: 10295 10 Side Road Front (southeast) Elevation (Town of Halton Hills 2024) 13

Figure 13: 10295 10 Side Road Entrance (Town of Halton Hills 2024) 13

Figure 14: 10295 10 Side Road Windows (Town of Halton Hills 2024) 13

Figure 15: 10295 10 Side Road Side (southwest) Elevation (Town of Halton Hills 2024) 14

Figure 16: 10295 10 Side Road Side (southwest) Elevation (Town of Halton Hills 2024) 14

Figure 17: 10295 10 Side Road Side (southwest) Elevation (Town of Halton Hills 2024) 15

Figure 18: 10295 10 Side Road Side (southwest) Elevation including nineteenth century addition (Town of Halton Hills 2024) 15

Figure 19: Agricultural fields looking east from subject property (Town of Halton Hills 2024) 15

Figure 20: Looking northeast from the subject property (Town of Halton Hills 2024) 16

Figure 21: Looking southwest from the subject property (Town of Halton Hills 2023) 16

Figure 22: Agricultural fields looking northeast from subject property (Town of Halton Hills 2024) 16

Figure 23: A Georgian Residence at 504 Main Street, Glen Williams. (Town of Halton Hills 2024) 17

Figure 24: A Georgian Residence at 510 Main Street, Glen Williams. (Google Street View 2023) 17

1.0 Property Description

10295 10 Side Road, Scotch Block	
Municipality	Town of Halton Hills
County or Region	Regional Municipality of Halton
Legal Description	PT LT 11, CON 5 ESQ, AS IN 248579; HALTON HILLS/ESQUESING
Construction Date	c.1856
Original Use	Residential
Current Use	Residential
Architect/Building/Designer	James Stewart
Architectural Style	Georgian
Additions/Alterations	Late 19th-century addition to rear
Heritage Status	Listed on the Town’s Heritage Register
Recorder(s)	Austin Foster; Laura Loney
Report Date	October 2024

2.0 Background

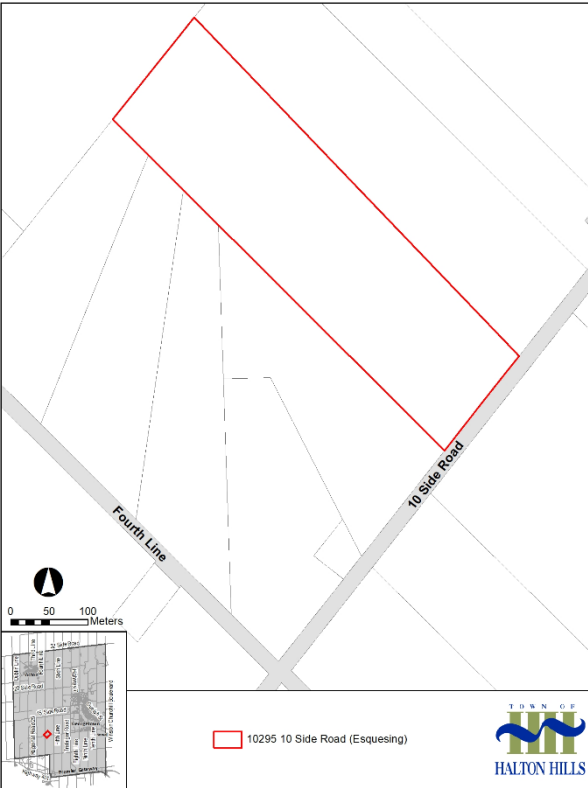

Figure 1: Subject Property identified on Location Map



Figure 2: Subject Property identified in Aerial Photograph

This research and evaluation report describes the history, context, and physical characteristics of the property at 10295 10 Side Road in Scotch Block, Halton Hills, Ontario (Figure 1 and Figure 2). The report includes an evaluation of the property’s cultural heritage value as prescribed by the *Ontario Heritage Act*.

2.1 Historical Background

Indigenous History Background

The enduring history of First Nation Peoples in Halton Hills can be traced back through time immemorial before contact with Europeans in the 1600s. Prior to the arrival of European settlers, the Credit River was central to Indigenous ways of life, supporting settlements, fisheries, horticulture, transportation, and trade. Iroquoian-speaking peoples, ancestors of the Wendat, occupied the Credit River Valley for hundreds of years until the mid-1600s, establishing semi-permanent villages. There are numerous archaeological sites in Halton Hills dating from this period, ranging from village sites to burial grounds, which reveal a rich cultural heritage. The Wendat were displaced by the Haudenosaunee around 1649-50 amid the conflicts that arose between European colonial powers and their First Nation allies.

The Mississaugas (part of the Anishinaabe Nation) arrived in southern Ontario in the 1690s, settling in two groups along the north shore of Lake Ontario and Lake Erie. The western group, occupying the area between Toronto and Lake Erie, became known as the Mississaugas of the Credit First Nation. Until the early 19th century, the Mississaugas of the Credit First Nation followed a seasonal cycle of movement and resource harvesting along the Credit River (Missinnihe, meaning "trusting creek"), and other rivers. In the winter months, extended family groups hunted in the Halton Hills area, travelling south towards the mouth of the river in the spring for the salmon run. The Mississaugas' fisheries and traditional economies were diminished because of increased Euro-colonial settlement, leading to a state of poverty and dramatic population decline.

In 1818, the British Crown negotiated the purchase of 648,000 acres of land from the Mississaugas of the Credit First Nation, including present-day Halton Hills, under the Ajetance Treaty (No. 19), named after Chief Ajetance. This left the Mississaugas with three small reserves on the Lake Ontario shoreline. The legitimacy of early land "surrenders" to the Crown is questionable when considering the Mississaugas' traditional understanding of property ownership. Unlike the British, the Mississaugas understood land in spiritual terms, and did not share the idea that access to land and resources could be given up permanently.

In 1986, the Mississaugas initiated a claim against the Government of Canada over the 1805 Toronto Purchase. On June 8, 2010, the parties involved reached a final compensatory agreement. It resulted in a cash payment of \$145 million to the Mississaugas of the Credit First Nation.¹

¹ This brief overview of Pre-Treaty Indigenous Territory within the land now known as Halton Hills is taken from the Town of Halton Hills' 2023 *Cultural Heritage Strategy*. This document includes additional recommendations relating to Truth and Reconciliation in Heritage Planning as part of the Town's commitment to advancing Truth and Reconciliation.

The Stewart Family

James Stewart (1787-1865), a Scottish immigrant from Blair Atholl, Scotland, arrived in Ontario in July 1818 with a letter of introduction from his home parish. He settled on Lot 11, Concession 5 in Esquesing Township, near the farm of his future father-in-law, John Stewart (1767-1854) (no relation), becoming one of the earliest settlers in the Scotch Block. Over the following decade, James cleared the land for agricultural purposes and constructed a log cabin on the property. The 1822 Patent Plan (Figure 3) identifies Stewart as the owner of Lot 11, Concession 5, though his settlement duties were not completed until the 1840s. In 1844, the Crown granted him the patent for the 200 acres of Lot 11. Actively involved in the local Presbyterian Church, James and his father-in-law advocated for the establishment of an officially sanctioned Scottish settlement in 1819. Their efforts resulted in the reservation of 6,000 acres for Scottish settlers, which became known as the Scotch Block, earning John and James Stewart the title of “the fathers of Scotch Block.”

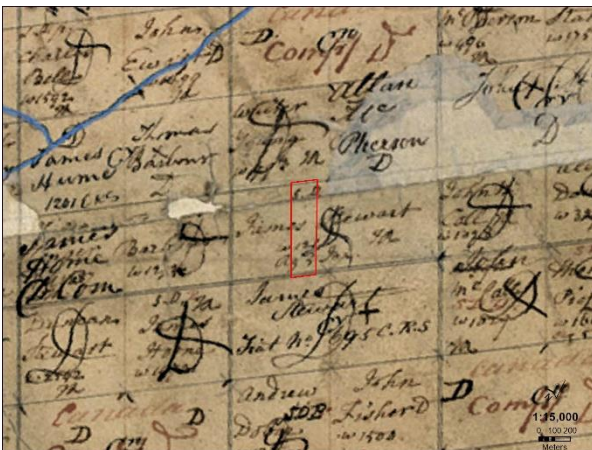

Figure 3: Subject property identified in red on 1822 Patent Plan

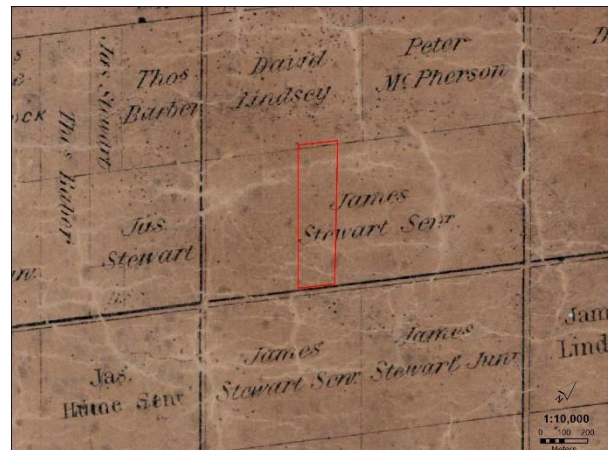

Figure 4: Subject property identified on the 1858 Tremain's Map of the County of Halton, Canada West

James married John Stewart’s daughter, Elizabeth Stewart (1800-1841) around 1825, and they had six children: John (1826-1860), Robert (1828-1918), Alexander (1831-1904), James Stewart Jr. (1832-1883), Margaret Elizabeth (1834-1918), and Christina Ann "Christy" (1840-1889). Elizabeth Stewart died in 1841. James re-married in 1847 to Janet McGregor (1814-1890), and they had two daughters: Janet (1848-1906) and Mary (1850-1938).

Between 1851 and 1855, James began building a Georgian-style residence on the subject property, later referred to as "Stewart's Castle." The home was constructed in 1856 using hand-pressed bricks from local clay. Stewart became wealthy through wheat sales to the British Commissariat and Transport Department during the Crimean War (1853-1856), using the profits to build his home and purchase additional land in the region. By the 1860s, James Stewart had expanded his land holdings to 385 acres, including a large sawmill and several large and productive farms in the region. The 1861 Agricultural Census provides a detailed account of James Stewart's property and accomplishments; of his 385 acres, 200 were under cultivation, 141 acres under crops, 59 acres under pasture, and 3 acres were orchards or

gardens. The total value of his farm was \$18,000, with \$400 in farm implements and machinery and \$925 in livestock.

James Stewart died on April 19, 1865. According to his will, the western half of Lot 11, Concession 5, was bequeathed to his daughters, Mary Stewart and Janet McKechnie. His widow, Janet, was allotted \$30 per year from land revenue, along with one cow, two sheep, the carriage and cutter, and a horse and harness. The brick house and orchard were left to Mary Stewart, on the condition that Janet would be allowed to live there for the remainder of her life, and that the land would be rented out to farmers until Mary married, at which point her husband would take over farming. The first tenant farmer was Adam Sproat in 1866. Additionally, twelve acres east of the brick house were reserved for Janet and her future husband to build a home, although this was never realized.

Widow Janet Stewart attempted to claim the eastern half of Lot 11, Concession 5; however, 50 acres of this portion were designated in James Stewart's will for his daughter Margaret (1834-1918), from his first marriage to Elizabeth. Margaret had married the farmer James Henderson Laidlaw (1831-1864) in 1859. The remaining 50 acres of the eastern half were to be sold by the will's executors to settle James' remaining debts.

Robert Stewart (1828-1918), James and Elizabeth's son, along with Janet Stewart, James' widow, contested the will, each making claims to more land than they had been allotted. In the winter of 1867, they sued the executors and trustees of James Stewart's will, with Robert alleging that the instructions within the will were obtained through "fraudulent misrepresentation and collusion."

The lawsuit resulted in a decree in Chancery in September 1868, which affirmed the distribution of ownership rights to the heirs and assigns as stipulated in James Stewart's will. The executors were named trustees of the eastern half of the property, which was transferred to Margaret Laidlaw and later sold to James Leslie in October of that year. A similar decree was issued for the western half of the property, with Mary Stewart and Janet McKechnie inheriting it in 1868. They retained ownership until 1896, with Mary Stewart listed as the owner in the 1877 *Illustrated Atlas of the County of Halton*. While Janet McKechnie retained co-ownership of the property, she relocated to her husband James McKechnie's (1849-1881) family farm at Lot 10, Concession 5 after their marriage around 1868.

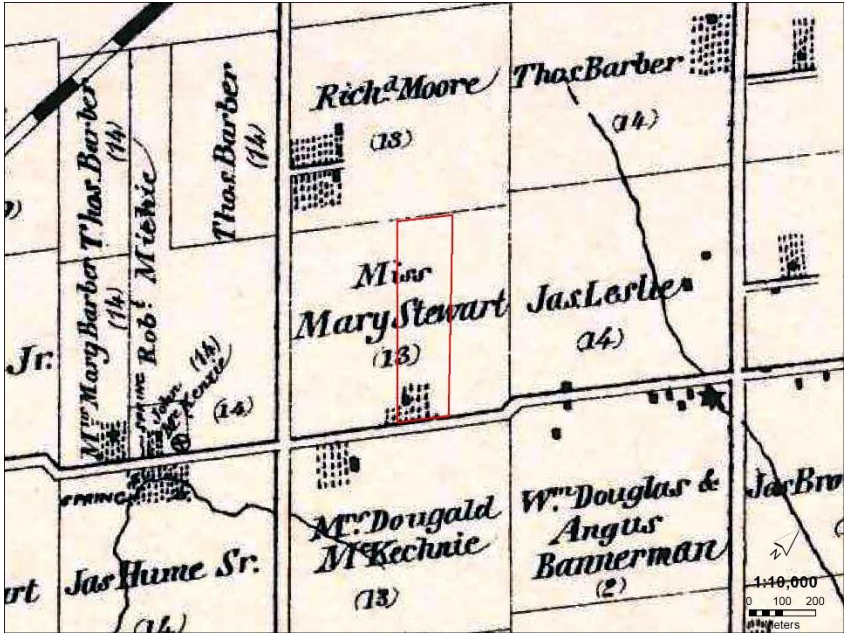

Figure 5: Mary Stewart identified as the owner of the subject property on the 1877 Halton County Atlas

Mary Stewart married farmer William Luxton Snow (1848-1891) in 1880. According to the 1881 census, Mary and William resided on the property with Janet Stewart, Mary’s mother. In 1883, Mary and William had their first and only daughter, Mary Ellen Snow (1883-1903), who died of tuberculosis at the age of 20. Janet Stewart died in 1890, and William Snow died shortly thereafter at the age of 42 in 1891. The subsequent 1891 census records Mary as the head of the household, a widowed farmer, living with her seven-year-old daughter.

The Huffman Family

In 1896, the property was transferred from Mary Snow and Janet McKechnie to John Robert Huffman (1859-1923), a Dutch Presbyterian farmer who owned the property until 1907. According to the 1901 census, John lived on the property with his twin brother Gideon Wesley Huffman (1859-1935) and sister Isabel "Isley" Huffman (1874-1900), and Gideon's wife and children. John never married and continued to live and work on the subject property after selling it to his brother in 1907. In October 1923, John Robert Huffman was crushed beneath one of his brother’s horses, suffering severe injuries to his head and ribs. He was found by his nephew, Gordon Huffman, and immediately taken to Guelph General Hospital where he died of a cerebral hemorrhage. His death was reported in the *Acton Free Press* on November 1, 1923.

Farmer Gideon Wesley Huffman purchased the subject property from his brother in 1907 and maintained ownership until his death in 1935. Gideon was an active member of the Boston Presbyterian Church and a prominent Liberal. He lived on the property with his wife, Annie McDonald (1872-1947), and their five children: Hazel (1898-1923), Donald (1899-1925), Pearl (1901-1979), Edith (1904-1988), and Allan (1905-1982). The 1931 census describes the house on the subject property as a twelve-room brick home valued at \$2000.

Gideon Huffman's death was announced in both the *Acton Free Press* on January 31, 1935, and the *Georgetown Herald* on January 30, 1935. Ownership of the subject property subsequently transferred to his wife, Annie McDonald Huffman, who owned it until 1951. Pearl Huffman then inherited the property and owned it until 1954 when she sold it to Daniel McCallum.

The subject property was described in 1951 as "The West Half of Lot Number Eleven in the Fifth Concession of the Township of Esquesing, the County of Halton, containing one hundred acres. The soil is a deep sandy clay loam. On the premises, there is said to be erected a two-storey solid brick house with 12 rooms, a frame barn 40x60, a frame horse stable on a stone foundation 30x64, a cow shed 24x60, a stone pig pen, and a frame driving shed" (*Georgetown Herald*, October 24, 1951, p. 9).

Tony Seynuck and Anthony Gas and Oil Exploration Company

In 1954, Tony Seynuck (1892-1967) purchased the subject property from McCallum with the intention of surveying gas and oil reserves. Originally from Ukraine, Seynuck immigrated to Canada from Romania in 1913 and had settled in Acton by 1919. He married Mary Woziak (1894-1973) in 1922 and opened a restaurant and ice cream store on Mill Street in Acton which he operated until 1928. Seynuck ventured into oil and gas exploration in 1930, forming the Suburban Gas and Oil Company. By 1940, he rebranded his enterprise to the Seynuck Valley Oil Company. Seynuck ran these companies from his Acton home at 151 Mill Street East.

In 1952 Seynuck discovered a significant natural gas deposit near Speyside, prompting him to acquire more property in the area for further exploration. In July of 1954, Seynuck found natural gas near Crewson's Corners, and in October, even more gas was discovered six miles south of Acton, near Speyside. Oil was later found in the same area. Residents gathered at both sites at night to watch the blue flame from the gas wells. Seynuck transported the equipment from McDonald's farm, located east of Highway 25 near Speyside, to Crewson's Corners and spent \$12,000 drilling at the site northwest of Acton. This find occurred at a depth of 2,100 feet, and Seynuck speculated that there was enough gas to "supply all of Ontario." In February of 1955, the third well in the Speyside area yielded 100,000 cubic feet. These discoveries led Seynuck to rebrand his company as Anthony Gas and Oil Explorations Limited in 1955. With this rebranding, he registered the company as a public entity, attracting local investors. The subject property was registered to Anthony Gas in 1955 and drilled for natural gas extraction for the rest of the decade.

Seynuck's company successfully extracted and sold gas throughout Southern Ontario throughout the 1950s and 1960s. However, his unexpected death in 1967 led to the company's liquidation and in August 1967, the property was sold to H. Morgan Self. In May 1968, Self auctioned off the farm equipment and much of the furniture and hardware from the Stewart House. He divided the property and subsequently sold the 25 acres that included the Stewart House, to the Howitt family in that same year.



Figure 6: Inauguration of natural gas in Georgetown (1956) (EHS p382f)

The Howitt Family

Richard "Dick" Howitt was a prominent local lawyer and politician. He graduated from the University of Western Ontario with a degree in History and English in the mid-1950s before attending law school at Osgoode Hall in Toronto. After being called to the bar in 1964, he pursued further legal studies in England. Returning to Canada, he worked for a Toronto law firm until 1973 when he established his own practice in Georgetown. Howitt specialized in real estate, corporate, and estate law, including wills and powers of attorney.

In addition to his legal career, Howitt was deeply involved in local politics and community service. Elected as a Councilor of Esquesing in 1970, he was appointed to the county planning board in 1971 and served as a regional councilor in 1975. In 1977, Howitt was appointed Queen's Counsel, a prestigious recognition of his contributions to the legal profession. He was also elected chairman of the Halton Hills Library Board in 1978 and served as an Esquesing Public School Board trustee in 1982. Throughout the 1980s and 1990s, Howitt was active with the Halton Conservation Authority, the Georgetown School Board, and the Halton Regional Board of Education, where he was elected as a trustee in 1985. He retired from the Georgetown school board in 1998. Dick Howitt and Carol Howitt owned the property from 1968 until 1998, when they sold it to their daughter.



Figure 7: Richard "Dick" Howitt, c. 1970. (MHS 4534)



Figure 8: Richard "Dick" Howitt, c. 1985. (MHS 2779)



Figure 9: The subject property at 10295 10 Side Road c.1990s (EHS 18311).



Figure 10: The subject property at 10295 10 Side Road c.1990s (EHS 18312).

2.2 Property & Architectural Description

The subject property is located at 10295 10 Side Road in the Town of Halton Hills. It is situated on a rectangular 24-acre lot that extends northwest from 10 Side Road, running parallel to Fourth Line. The property features a two-storey Georgian farmhouse and a barn, both set within an agricultural landscape. Access to the dwelling is provided by an unpaved driveway from 10 Side Road. The legal description of the property is PT LT 11, CON 5 ESQ, AS IN 248579; HALTON HILLS/ESQUESING.



Figure 11: Aerial Photograph of 10295 10 Side Road (Town of Halton Hills, 2024)

The extant building on the subject property is a two-storey Georgian residence constructed on a rectangular plan using local, hand-pressed red-brick laid in a Flemish bond pattern. The front (southeast) elevation exhibits typical characteristics of Georgian and Georgian Revival architecture, featuring a highly symmetrical design with graduated fenestration and a hipped roof. The front elevation is divided into five symmetrical bays. Red-brick chimneys are located at either end of the building, rising above the roofline and flanking this elevation.



Figure 12: 10295 10 Side Road Front (southeast) Elevation (Town of Halton Hills 2024)

The first storey of the front (southeast) elevation features four rectangular window openings, with two symmetrically situated on either side of the central entrance featuring flatheaded window openings with limestone lintels and sills. The central entrance is similarly capped with a limestone lintel and flanked by sidelight windows. The fenestration follows a graduated pattern, with five windows on the second floor that are slightly shorter than those on the first floor, featuring flatheaded window openings with limestone lintels and sills. The middle window on the second floor is centered above the first-storey entrance. A series of white wooden modillions run along the cornice.



Figure 13: 10295 10 Side Road Entrance (Town of Halton Hills 2024)



Figure 14: 10295 10 Side Road Windows (Town of Halton Hills 2024)



Figure 15: 10295 10 Side Road Side (southwest) Elevation (Town of Halton Hills 2024)



Figure 16: 10295 10 Side Road Side (southwest) Elevation (Town of Halton Hills 2024)

The side (southwest) elevation of the dwelling is divided into three sections, with a late nineteenth century addition creating an H-plan configuration. The structure is segmented into three distinct parts: the right wing (southernmost), the center block, and the left wing (northernmost). The center block is recessed between the two projecting wings.

The right wing, which is the original section of the residence, is bisected by a centrally located chimney. On the first floor, a single rectangular window opening with a limestone sill and lintel is positioned on the southwest half of the wall. The second-floor features two symmetrical windows with limestone sills and lintels; however, the southeasternmost window has been infilled with brick. Classical detailing is visible in the wooden modillions that adorn each corner of the cornice.

The center block features a covered porch, accessed by a flight of stairs leading to the side entrance of the home, emphasizing the formal entryway. Above the porch, second-floor windows from both wings align, facing each other over the porch roof.

The ground floor of the left wing includes a single window opening with a limestone lintel, centrally positioned within the wall. The second floor originally mirrored this design, with a corresponding window directly above, but this upper window has since been infilled with brick. Despite the modifications, the overall proportions of the original structure and each wing remain highly symmetrical, particularly with the balanced placement of the central chimney in the right wing.



Figure 17: 10295 10 Side Road Side (southwest) Elevation (Town of Halton Hills 2024)



Figure 18: 10295 10 Side Road Side (southwest) Elevation including nineteenth century addition (Town of Halton Hills 2024)



Figure 19: Agricultural fields looking east from subject property (Town of Halton Hills 2024)



Figure 20: Looking northeast from the subject property (Town of Halton Hills 2024)



Figure 21: Looking southwest from the subject property (Town of Halton Hills 2023)



Figure 22: Agricultural fields looking northeast from subject property (Town of Halton Hills 2024)

2.3 Architectural Style & Comparative Analysis

Georgian residential architecture was prevalent in Ontario from the late-eighteenth century through the mid-nineteenth century, particularly between 1780 and 1860. This style, rooted in classical proportions and symmetry, was brought to Canada by British settlers and United Empire Loyalists, and became a dominant architectural expression in early colonial settlements.

According to John Blumenson's *Ontario Architecture: A Guide to Styles and Building Terms, 1784 to the Present*, typical features characteristic of the Georgian style in Ontario include:

- Symmetrical Facades: The front elevation is highly symmetrical, often centered around a prominent entrance with neo-classical detailing;

- Hipped or Gabled Roofs: Georgian homes typically feature hipped roofs, though gabled roofs are also common;
- Graduated Fenestration: Windows are symmetrically arranged, with larger windows on the ground floor and smaller ones above, often featuring multi-paned sash windows;
- Brick or Stone Construction: Georgian homes are commonly constructed of brick or stone, with bricks often laid in a Flemish bond pattern;
- Classical Detailing: Features such as modillions under the eaves, limestone lintels above windows and doors, cornice with modillion blocks, moulded window surrounds, pedimented porticos; and,
- Chimneys: Symmetrically placed chimneys are a hallmark of Georgian architecture, often located at the center of side elevations.

The property at 10295 10 Side Road is a rare example of a two-storey Georgian rural home within the Town of Halton Hills and is an excellent example of Georgian architecture in the community, exhibiting many of the style’s defining characteristics. The two-storey Georgian home features a symmetrical front elevation with graduated fenestration, typical of the Georgian style. The hipped roof, limestone lintels and sills, and white modillions along the cornice further emphasize the classical detailing of the period. The use of locally sourced and fired red brick in the construction is representative of the traditional building materials associated with Georgian architecture in Ontario.

There are currently several properties on the Town’s Heritage Register identified as Georgian style, dating from the early to mid-nineteenth century. Within the Halton Hills area, properties such as 504 (Figure 24) and 510 Main Street (Figure 25) in Glen Williams are comparable in terms of form, materials, and design. However, the property’s long-standing role as a rural residence and its connection to the early settlement history of the Scotch Block, distinguishes it from other Georgian-style buildings in the region.



Figure 23: A Georgian Residence at 504 Main Street, Glen Williams. (Town of Halton Hills 2024)



Figure 24: A Georgian Residence at 510 Main Street, Glen Williams. (Google Street View 2023)

Though some alterations have occurred, such as the infilling of certain windows on the side elevation, and an addition to the rear elevation, the property has retained its architectural integrity. It has remained in its original location for over 170 years, continuing to serve as a residence, and stands as a

significant example of Georgian architecture within an agricultural landscape. This enduring presence, combined with its well-preserved Georgian features, solidifies the property's importance in the architectural and historical narrative of Halton Hills.

3.0 Description of Heritage Attributes and Evaluation Checklist

The following evaluation checklist applies to Ontario Regulation 9/06 made under the *Ontario Heritage Act*: Criteria for Determining Cultural Heritage Value or Interest. The criteria are prescribed for municipal designation of Heritage Properties under Part IV, Section 29 of the *Ontario Heritage Act*. The evaluation tables utilize an 'X' to signify applicable criteria and 'N/A' to signify criteria that are not applicable for this property.

Design or Physical Value	
Is rare, unique, representative, or early example of a style, type, expression, material, or construction method	X
Displays a high degree of craftsmanship or artistic merit	N/A
Demonstrates a high degree of technical or scientific achievement	N/A

The property at 10295 10 Side Road is a representative example of Georgian architecture, characterized by its symmetry, classical proportions, graduated fenestration, and classical detailing. The two-storey Georgian farmhouse, constructed with locally sourced and fired redbrick, features a symmetrical front facade, a hallmark of the Georgian style. The graduated fenestration, limestone lintels and sills, and white wooden modillions under the eaves emphasize the classical detailing typical of Georgian architecture. The central doorway, flanked by sidelights and capped with a limestone lintel serves as the focal point of the front elevation, aligning with the second-floor window openings, reinforcing the symmetry and balance inherent to Georgian design. The residence on the subject property is an excellent rare surviving example of a rural Georgian home in Halton Hills.

Historical or Associative Value	
Has direct associations with a theme, event, belief, person, activity, organization, or institution that is significant to a community	X
Yields, or has potential to yield, information that contributes to an understanding of a community or culture	N/A
Demonstrates or reflects the work or ideas of an architect, artist, builder, designer, or theorist who is significant to a community	N/A

The property at 10295 10 Side Road holds historical and associative value due to its multi-generational connection with the Stewart family, prominent figures in the early settlement of the Scotch Block in Esquesing Township. James Stewart, a Scottish immigrant who contributed to the establishment of Scotch Block as a community for Scottish settlers, acquired the property in 1844. The Stewart family was responsible for contributing to the areas social, agricultural, and economic development, using the property to establish a sawmill and several farmsteads.

The property was later owned by several of Stewart's descendants, who became prominent figures in Scotch Block. Subsequent owners, such as the Huffman, Seynuck, and Howitt families, further contribute to the property's historical significance. While living in Scotch Block, Gideon Huffman was an active member of the Boston Presbyterian Church, and an outspoken Liberal. Tony Seynuck successfully established Anthony Gas and Oil Exportations Limited, extracting and selling gas throughout Southern Ontario through the 1950s and 1960s, contributing to the Region's industrial growth in the mid-

twentieth century. Richard Howitt was involved in local politics serving as a Halton Regional Councillor, while also acting as a member of the Halton Conservation Authority, and a trustee of the Halton Regional Board of Education.

The property's association with the Stewart family and its role in the broader narrative of the Scotch Block's development solidify its historical and associative value. The dwelling on the subject property is one of the oldest extant residential buildings in the Town.

Contextual Value	
Is important in defining, maintaining, or supporting the character of an area	X
Is physically, functionally, visually, or historically linked to its surroundings	X
Is a landmark	N/A

The property at 10295 10 Side Road holds significant contextual value as it serves to define and maintain the early nineteenth century agricultural character of Scotch Block. The Georgian farmhouse, set within a pastoral landscape, visually anchors the historical rural identity of Scotch Block and the surrounding community, reflecting the agricultural roots that have shaped the local community for generations. The farmhouse's traditional design and construction methods embody the area's historical development, serving as a tangible link to early settlers who established the Scotch Block. Having remained in its original location for over 170 years, the property remains physically and visually connected to its surroundings. The property has not been identified as a landmark.

4.0 Summary

Following research and evaluation according to Ontario Regulation 9/06, it has been determined that the property at 10295 10 Side Road has physical and design, historical and associative, and contextual value and therefore meets Ontario Regulation 9/06 criteria for determining cultural heritage value or interest.

The heritage attributes of the property at 10295 10 Side Road are identified as follows:

- The location, setting, and agricultural context of the property at 10295 10 Side Road in the Town of Halton Hills;
- The scale, form, and massing of the two-storey Georgian farmhouse, including its symmetrical front elevation;
- The materials used in the construction, including locally sourced and fired redbrick, and limestone;
- The front (southeast) elevation, including:
 - The symmetrical design divided into five bays with graduated fenestration, including two rectangular window openings on either side of the central entrance and five vertically aligned rectangular window openings on the second storey;
 - Limestone windowsills and lintels;
 - Central entrance set within a flatheaded opening, flanked by sidelights and capped with a limestone lintel;
 - Hipped roof with wooden modillions along the cornice;
 - Symmetrically placed chimneys flanking the front elevation;
- The side (southwest) elevation, including:
 - Rectangular double-hung sash windows with limestone sills and lintels, symmetrically placed on either side of the centrally located chimney on the right wing; and,

- Wooden modillions along the cornice.

The rear elevation, and side (northeast) elevation, and interiors have not been identified as heritage attributes of the property as part of this report. The northeast side elevation and rear elevation are currently unobservable and inaccessible from the public right of way. However, further investigation may provide an opportunity to identify additional heritage attributes.

5.0 Sources

Primary Sources

Census of Canada: 1891; Census Place: Esquesing, Halton, Ontario, Canada; Roll: T-6340; Family No: 79.

Census of Canada: 1891; Census Place: Esquesing, Halton, Ontario, Canada; Roll: T-6340; Family No: 80.

Census of Canada: 1901; Census Place: Esquesing, Halton, Ontario; Page: 11; Family No: 111.

Census of Canada: 1911; Census Place: 1 - Esquesing, Halton, Ontario; Page: 8; Family No: 81.

Census of Canada: 1911; Census Place: 3 - Esquesing, Halton, Ontario; Page: 1; Family No: 2.

Census of Canada: 1881; Census Place: Esquesing, Halton, Ontario; Roll: C_13258; Page: 40; Family No: 177.

'Division Registrar Vital Statistics Records, 1858-1930.' Archives of Ontario. MS 940, reels 5-10, 16, 21, 26-27. Archives of Ontario, Toronto, Ontario, Canada.

Library and Archives Canada; Ottawa, Ontario, Canada; Seventh Census of Canada, 1931; Folder Number: T-27267; Census Place: Halton, Ontario, Canada; Page Number: 8.

Concession 5 Esquesing Township. Halton County Land Records. (LRO20: Ontario).

"Halton Surrogate Court Records. Stewart James, Probate of Will, vol. A, page 77-80, Instrument Number 36. Folio Number: A-B 1851-1877."

Halton Surrogate Court Records. Stewart James, Esquesing, Probate of Will, vol. A, page 444-446, Instrument Number 289. Folio Number: A-B 1851-1877.

Halton Surrogate Court Records. Stewart James, Esquesing, Letters of Administration, vol. A, page 481, Instrument Number 323. Folio Number: A-B 1851-1877.

Registrations of Deaths, 1923; Archives of Ontario; Toronto, Ontario, Canada; Series: 301.

Registrations of Deaths, 1869-1942 Archives of Ontario. (MS 935, reels 1-694), Archives of Ontario, Toronto, Ontario, Canada.

Registrations of Deaths, 1938; Archives of Ontario; Toronto, Ontario, Canada; Series: 614.

Registration of marriages 1869-1928. Archives of Ontario; Toronto, Ontario, Canada; Reel: 33.

Registrations of Ontario Overseas Deaths, 1939-1947. Archives of Ontario. MS 944, reels 1-11. Archives of Ontario, Toronto, Ontario, Canada.

Newspapers:

- "Administrators sale." *Georgetown Herald* (Georgetown, ON), January 16, 1924, p. 4.
[Georgetown Herald \(Georgetown, ON\), January 16, 1924, p. 4: Halton Hills Newspapers \(halinet.on.ca\)](#)
- "Anthony Gas and Oil Explorations." *Georgetown Herald* (Georgetown, ON), June 8, 1955, p. 11.
<https://news.haltonhills.halinet.on.ca/91266/page/11?q=Anthony+Gas&docid=OOI.91266>
- "Anthony Seynuck Dies at 75." *Acton Free Press* (Acton, ON), December 13, 1967, p. 3.
[Acton Free Press \(Acton, ON\), December 13, 1967, p. 3: Halton Hills Newspapers \(halinet.on.ca\)](#)
- "Clearing Auction." *Georgetown Herald* (Georgetown, ON), May 30, 1968, p. 17.
[Georgetown Herald \(Georgetown, ON\), May 30, 1968: Halton Hills Newspapers \(halinet.on.ca\)](#)
- "Council Pressed for Gas Franchise from Two Sides." *Acton Free Press* (Acton, ON), July 21, 1955, p. 1.
[Acton Free Press \(Acton, ON\), July 21, 1955, p. 1: Halton Hills Newspapers \(halinet.on.ca\)](#)
- "Dick Howitt Appointed to queens council." *Georgetown Herald* (Georgetown, ON), January 5, 1977, p. 1.
[Georgetown Herald \(Georgetown, ON\), January 5, 1977, p. 1: Halton Hills Newspapers \(halinet.on.ca\)](#)
- "Dick Howitt chairman of Library Board." *Acton Free Press* (Acton, ON), January 18, 1978, p. 19.
[Georgetown Herald \(Georgetown, ON\), November 10, 1982, p. 1: Halton Hills Newspapers \(halinet.on.ca\)](#)
- "Died: Huffman." *Acton Free Press* (Acton, ON), October 25, 1900, p. 2.
[Acton Free Press \(Acton, ON\), October 25, 1900, p. 2: Halton Hills Newspapers \(halinet.on.ca\)](#)
- "Esquesing Council Briefs." *Acton Free Press* (Acton, ON), April 21, 1971, p. 7.
[Acton Free Press \(Acton, ON\), April 21, 1971: Halton Hills Newspapers \(halinet.on.ca\)](#)
- "Gas Riches may Await the Gambler." *Acton Free Press* (Acton, ON), February 20, 1980, p. 1.
[Acton Free Press \(Acton, ON\), February 20, 1980, p. 1: Halton Hills Newspapers \(halinet.on.ca\)](#)
- "Howitt Exits with a Smile." *Independent & Free Press* (Georgetown, ON), January 11, 1998, p. 3.
[Independent & Free Press \(Georgetown, ON\), 11 Jan 1998, p. 3: Halton Hills Newspapers \(halinet.on.ca\)](#)
- "Maltby Fills Vacant Council Seat." *Acton Free Press* (Acton, ON), August 27, 1975, p. 1.
[Acton Free Press \(Acton, ON\), August 27, 1975, p. 2: Halton Hills Newspapers \(halinet.on.ca\)](#)
- "Pair of Horses: J.R. Huffman." *Acton Free Press* (Acton, ON), October 10, 1901, p. 1.

[Acton Free Press \(Acton, ON\), October 10, 1901: Halton Hills Newspapers \(halinet.on.ca\)](#)

"Two Companies seek Natural Gas Franchise." *Georgetown Herald* (Georgetown, ON), April 6, 1955, p. 1.

[Georgetown Herald \(Georgetown, ON\), April 6, 1955, p. 1: Halton Hills Newspapers \(halinet.on.ca\)](#)

"Two New Faces on Esquesing's 71-72 Council." *Georgetown Herald* (Georgetown, ON), December 10, 1970, p. 20.

[Georgetown Herald \(Georgetown, ON\), December 10, 1970, p. 20: Halton Hills Newspapers \(halinet.on.ca\)](#)

"Ward 1 and 2 school board trustees." *Georgetown Herald* (Georgetown, ON), October 27, 1982, p. 8.

[Georgetown Herald \(Georgetown, ON\), October 27, 1982, p. 8: Halton Hills Newspapers \(halinet.on.ca\)](#)

"Strange fatal accident last week." *Acton Free Press* (Acton, ON), November 1, 1923, p. 1

[Acton Free Press \(Acton, ON\), November 1, 1923, p. 1: Halton Hills Newspapers \(halinet.on.ca\)](#)

Secondary Sources

Ancestry.com. Canada, Find a Grave® Index, 1600s-Current [database on-line]. Lehi, UT, USA: Ancestry.com Operations, Inc., 2012.

Beaton, Joyce. "Georgian architecture in gracious old home." *Georgetown Independent*, February 13, 1974, P. 13-15.

Blumenson, John. Ontario architecture : a guide to styles and building terms, 1784 to the present. Toronto: Fitzhenry & Whiteside, 1990.

Dills, Jim and Brown, Gloria. *Halton's Scotch Block: The People and Their Stories*. Milton Historical Society: Milton, 2009.

"R.A. Lawyers: Richard Howitt." <https://www.ralawyers.ca/richard-howitt>.

Research and Evaluation Report



(Town of Halton Hills 2024)

Noble-Pomeroy House

12 & 14 Adamson Street North, Norval, Town of Halton Hills

October 2024

Project Personnel

Report Authors

Austin Foster MA,
Cultural Heritage Assistant

with

Laura Loney, MPlan, MCIP, CAHP, RPP
Manager of Heritage Planning

Historical Research

Laura Loney

Austin Foster

Field Review

Austin Foster

Laura Loney

Report Preparation

Austin Foster

Laura Loney

Mapping Graphics:

Rehan Waheed, MA
Planning Data Analyst

Report Reviewers:

Caylee MacPherson
Planner – Development Review & Heritage

Bronwyn Parker
Director of Planning Policy

John Linhardt
Commissioner of Planning & Development

Table of Contents

1.0 Property Description.....	5
2.0 Background	5
2.1 Historical Background	6
2.2 Property & Architectural Description	15
2.2 Architectural Style & Comparative Analysis.....	18
3.0 Description of Heritage Attributes and Evaluation Checklist.....	21
4.0 Summary	22
5.0 Sources.....	23

Table of Figures

Figure 1: Location Map - 12 & 14 Adamson Street North	5
Figure 2: Aerial Photograph - 12 & 14 Adamson Street North	5
Figure 3: Subject property identified on the 1822 Patent Plan	7
Figure 4: Portrait of General Peter Adamson, c.1850s (Mississauga Library BA0201).....	8
Figure 5: The Norval Flour Mill c. 1900 (EHS 10187)	9
Figure 6: A 1909 advertisement for Norval Mills (Georgetown Herald, February 24, 1909, p.1.).....	9
Figure 7: Portrait of Alexander Noble and his family c.1920 (McDonald, <i>Halton Sketches Revisited</i> , 2002).....	9
Figure 8: Colonel Alexander Laing Noble on his 96th birthday on February 18, 1963. (EHS 06683)	9
Figure 9: Subject property identified on Tremaine’s 1858 <i>Map of the County of Halton, Canada West</i> ..	10
Figure 10: Subject property identified on the 1877 Illustrated Historical Atlas of the County of Halton ..	10
Figure 11: A view of Noble’s Grist Mill C.1910 (EHS p10194f).....	11
Figure 12: Village Map of Norval c. 1920, subject property identified in red. Inhabitants of subject property are identified as Maggie Bird and John Slingsby (EHS ON00098 MG1 A9)	11
Figure 13: Subject property identified on the 1926 Birds Eye View of Norval (Artist’s Impression) (MG12 A2.05)	12
Figure 14: Subject property identified in 1952 ortho-imagery; note the newly completed boat works. (Town of Halton Hills, 2024)	13
Figure 15: A photograph of Bill Pomeroy’s Credit River Boat Co. in 1989(<i>Georgetown Herald</i> , April 26, 1989, p. 50)	14
Figure 16: An advertisement for Bill Pomeroy’s Credit River Boat Company (<i>Acton Free Press</i> , March 21, 1979, p. 9)	14
Figure 17: Portrait of the 1982 Halton Hills Council. Peter Pomeroy was Mayor (seated at desk). (EHS 00380).....	14
Figure 18: Portrait of Peter Pomeroy, Chairman of Halton Regional Council in 1990 (EHS 16875).....	14
Figure 19: Subject property identified in 2002 aerial photography.....	15
Figure 20: Subject property identified in 2011 aerial photography.....	15
Figure 21: Subject Property identified in 2023 aerial photography.....	15
Figure 22: Looking South down Adamson Street North from Subject Property (Google Street View 2024)	16

PT LT 11, CON 11 ESQ, AS IN 699558; EXCEPT PTS 1 AND 3 PL 20R20891; S/T 341253; S/T & T/W 415289; HALTON HILLS/ESQUESING

Figure 23: Looking North up Adamson Street North from Subject Property (Google Street View 2024) .. 16

Figure 24: Front (west) elevation of the existing building at 12 & 14 Adamson Street North (Town of Halton Hills 2024) 16

Figure 25: Side (south) elevation of the existing building at 12 & 14 Adamson Street North (Town of Halton Hills 2024) 17

Figure 26: Side (north) elevation of the existing building at 12 & 14 Adamson Street North (Town of Halton Hills 2024) 18

Figure 27: c.1860s duplex at 12 and 14 Noble Street (Google Street View 2023) 20

Figure 28: c. 1870s Gothic Revival style duplex at the modern addresses of 128 & 130 Main Street South in Georgetown (Town of Halton Hills 2024) 20

Figure 29: 10 Noble Street, Norval (Town of Halton Hills 2024) 20

Figure 30: 484 Guelph Street, Norval (Google Street View 2023) 20

PT LT 11, CON 11 ESQ, AS IN 699558; EXCEPT PTS 1 AND 3 PL 20R20891; S/T 341253; S/T & T/W 415289; HALTON HILLS/ESQUESING

1.0 Property Description

12 & 14 Adamson Street North, Norval	
Municipality	Town of Halton Hills
County or Region	Regional Municipality of Halton
Legal Description	PT LT 11, CON 11 ESQ, AS IN 699558; EXCEPT PTS 1 AND 3 PL 20R20891; S/T 341253; S/T & T/W 415289; HALTON HILLS/ESQUESING
Construction Date	c.1870
Original Use	Residential
Current Use	Residential
Architect/Building/Designer	Robert Noble
Architectural Style	Gothic Revival
Additions/Alterations	Modern Addition to Rear Elevation
Heritage Status	Listed on the Town’s Heritage Register
Recorder(s)	Austin Foster
Report Date	October 2024

2.0 Background

This research and evaluation report describes the history, context, and physical characteristics of the property at 12 & 14 Adamson Street North in Norval, Halton Hills, Ontario. The report includes an evaluation of the property’s cultural heritage value as prescribed by the *Ontario Heritage Act*.

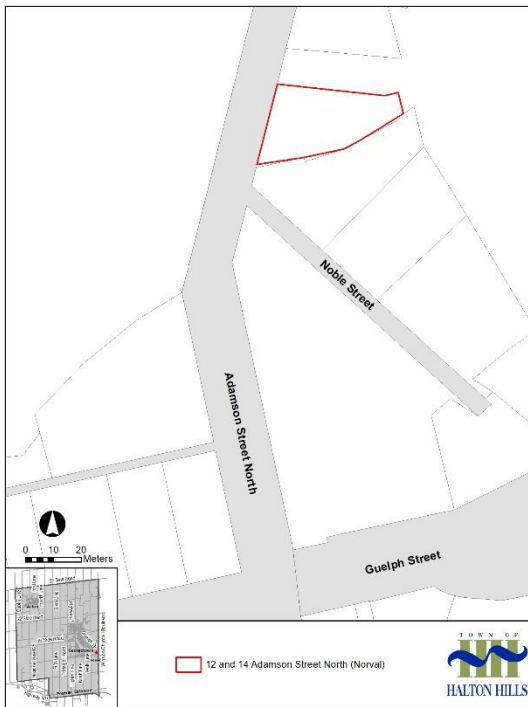

Figure 1: Location Map - 12 & 14 Adamson Street North



Figure 2: Aerial Photograph - 12 & 14 Adamson Street North

2.1 Historical Background

Indigenous History Background

The enduring history of First Nation Peoples in Halton Hills can be traced back through time immemorial before contact with Europeans in the 1600s. Prior to the arrival of European settlers, the Credit River was central to Indigenous ways of life, supporting settlements, fisheries, horticulture, transportation, and trade. Iroquoian-speaking peoples, ancestors of the Wendat, occupied the Credit River Valley for hundreds of years until approximately the mid-1600s, establishing semi-permanent villages. There are numerous archaeological sites in Halton Hills dating from this period, ranging from village sites to burial grounds, which reveal a rich cultural heritage. The Wendat were displaced by the Haudenosaunee around 1649-50 amid the conflicts that arose between European colonial powers and their First Nation allies. The Mississaugas (part of the Anishinaabe Nation) arrived in southern Ontario in the 1690s, settling in two groups along the north shore of Lake Ontario and Lake Erie. The western group, occupying the area between Toronto and Lake Erie, became known as the Mississaugas of the Credit First Nation. Until the early 19th century, the Mississaugas of the Credit First Nation followed a seasonal cycle of movement and resource harvesting along the Credit River (Missinnihe, meaning "trusting creek"), and other rivers. In the winter months, extended family groups hunted in the Halton Hills area, travelling south towards the mouth of the river in the spring for the salmon run. The Mississaugas' fisheries and traditional economies were diminished as a result of increased Euro-colonial settlement, leading to a state of impoverishment and dramatic population decline.

In 1818, the British Crown negotiated the purchase of 648,000 acres of land from the Mississaugas of the Credit First Nation, including present-day Halton Hills, under the Ajetance Treaty (No. 19), named after Chief Ajetance. This left the Mississaugas with three small reserves on the Lake Ontario shoreline. The legitimacy of early land "surrenders" to the Crown is questionable when considering the Mississaugas' traditional understanding of property ownership. Unlike the British, the Mississaugas understood land in spiritual terms, and did not share the idea that access to land and resources could be given up permanently.

In 1986, the Mississaugas initiated a claim against the Government of Canada over the 1805 Toronto Purchase. On June 8, 2010, the parties involved reached a final compensatory agreement. It resulted in a cash payment of \$145 million to the Mississaugas of the Credit First Nation.¹

Early European Settlement and James McNab

In 1824, the patent for the east half of Lot 11, Concession 11 in Esquesing Township was granted to Robert Miller (1797-1877). In 1825, Miller sold the eastern half of Lot 11 to John McNab (1758-1846) and his son, James McNab (1787-1866).

¹ This brief overview of Pre-Treaty Indigenous Territory within the land now known as Halton Hills is taken from the Town of Halton Hills' 2023 *Cultural Heritage Strategy*. This document includes additional recommendations relating to Truth and Reconciliation in Heritage Planning as part of the Town's commitment to advancing Truth and Reconciliation.



Figure 3: Subject property identified on the 1822 Patent Plan

John McNab was born in Glen Orchy, Scotland in 1758. Working as a weaver in Paisley, McNab married Janet Fletcher (1763-1811), and together they emigrated to Barnet, Vermont in 1785. The couple had eight children: John (1784-1878), James (1787-1866), Jane (1798-1871), Alexander (1791-1856), Mary (1793-1835), Archibald (1801-1870), Janet (1798-1835), and Duncan (1803-1869). Following Janet's death in 1811, the family settled in Upper Canada. John McNab and his children had established themselves in Esquesing Township by 1819. In 1822, John McNab was granted the patent for the west half of Lot 12, Concession 11.

James McNab served as a Lieutenant with the York Volunteers during the War of 1812, participating in the Battle of Queenston Heights and the defense of Fort George. Following his discharge in 1815, James began farming with his father. In 1825, James and his father purchased one hundred acres of Lot 11, Concession 11 from Robert Miller. Between 1826 and 1830, James and his brother, Alexander McNab, constructed a grist mill, sawmill, and wool mill along the Credit River. In addition to the mill, the McNab family built a farmhouse across the Credit River, known as the "McNab Farmhouse" or "Elm's House" (now 10184 Winston Churchill Boulevard). In 1827, James placed an advertisement in Mackenzie's *Colonial Advocate*, encouraging craftsmen and tradesmen to come to their Esquesing Mills.

In 1830, James McNab suffered a severe injury at the mill, leading to the amputation of his leg. While recovering, McNab leased the mills to John Barnhart but resumed management in 1834. During the 1837 Rebellion, he served as a Captain in Chippewa and Toronto. After returning to Esquesing in 1838, he sold the mills and surrounding land to General Sir Peter Adamson (1775-1865) to cover his war debts, and Adamson appointed his son-in-law, Colonel Charles Mitchell (1802-1891), to run the mills.

Peter Adamson

Sir Peter Adamson served as a colonel in the Portuguese Army during Wellington's peninsular offensive against Napoleon. For his military service, the Portuguese government named him Knight of the Tower and Sword, and the British government awarded him land in western Ontario. After purchasing the mills and farmland from the McNab family, Adamson commissioned a survey to lay out Norval in streets and village lots. From 1845 to 1858, Adamson leased the Norval Mills to Gooderham and Worts, which operated a distillery and ashery in the valley behind Hillcrest Cemetery and added a flax mill near the grist mill.



Figure 4: Portrait of General Peter Adamson, c.1850s (Mississauga Library BA0201)

Colonel Charles Mitchell, however, lost the Norval Mills property to the Bank of Ontario in 1868, shortly after Peter Adamson's death in 1865 at the age of 89.

The Noble Family

In 1868, the Norval mills were purchased from the Bank of Ontario by Robert Noble (1835-1908), who had emigrated from Carlisle, Cumberland, England, to Dundas in 1852, then to Norval by 1868. Noble leased the woolen mill to William Grant while maintaining ownership of the flour mill, which he developed into a successful and profitable business.

Between 1876 and 1881, Robert Noble, along with his son, Alexander Laing Noble (1867-1963), oversaw a steady increase in flour production, continuously upgrading and modernizing their mills on Lot 11, Concession 11. The Nobles became prominent in the Canadian flour industry, known throughout the Dominion and internationally for their "Norval" pastry flour and "King's Choice" bread flour. As the business grew, the Nobles expanded the mill's infrastructure and staff. In 1880, Noble rebuilt the mills, and by 1899, he had upgraded the millstones to the modern roller system. In 1909, the Grand Trunk Railway reported that an average of 700 barrels of flour were being transported daily from Noble Mills to the station.



Figure 5: The Norval Flour Mill c. 1900 (EHS 10187)



Figure 6: A 1909 advertisement for Norval Mills (Georgetown Herald, February 24, 1909, p.1.)



Figure 7: Portrait of Alexander Noble and his family c.1920 (McDonald, *Halton Sketches Revisited*, 2002)



Figure 8: Colonel Alexander Laing Noble on his 96th birthday on February 18, 1963. (EHS 06683)

As the Noble family expanded the mills, it became necessary to construct more residences in Norval to house their growing workforce. The extant dwelling on the subject property was likely built to house mill workers during Robert Noble's ownership of the business and subject property between 1868 and 1881. At this time, the residence on Lot 11, Concession 11, occupied the same property as Noble's Mills and the Noble House (completed around 1869). The property had not yet been severed or registered as a separate village lot.

PT LT 11, CON 11 ESQ, AS IN 699558; EXCEPT PTS 1 AND 3 PL 20R20891; S/T 341253; S/T & T/W 415289; HALTON HILLS/ESQUESING

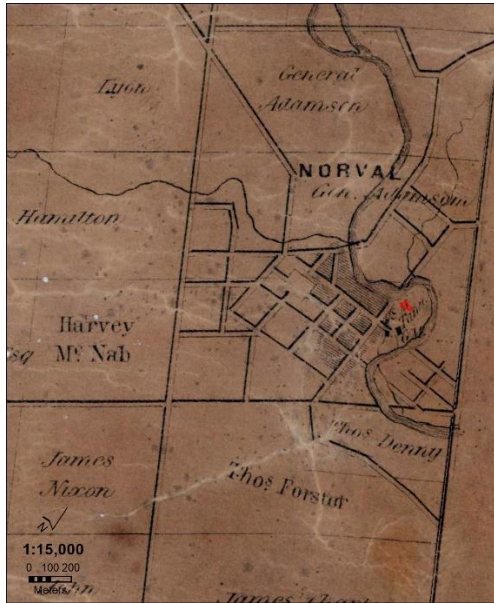

Figure 9: Subject property identified on Tremaine's 1858 Map of the County of Halton, Canada West

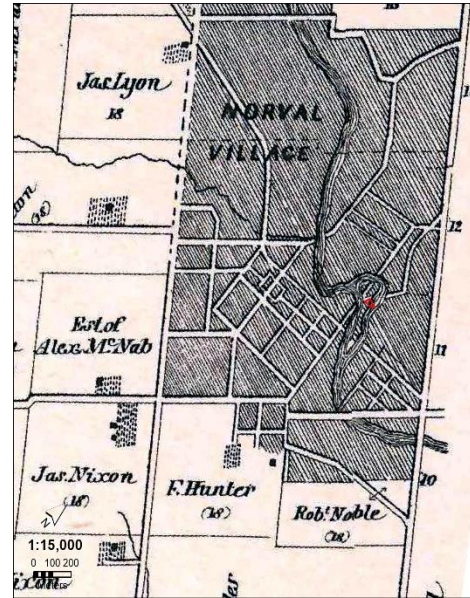

Figure 10: Subject property identified on the 1877 Illustrated Historical Atlas of the County of Halton

In 1919, the mill was sold to W.J. Campbell Ltd., however the McNab farmhouse, the residences at 12-14 Adamson, and the house at 10 Noble Street remained owned by the Noble family. Between 1905 and 1919, Alexander Noble purchased the subject property from Robert Noble and rented out the residence to several families including the Slingsby family, who had moved to the subject property around 1911.

Slingsby and Bird

John William Slingsby (1869-1959) was married to Mary Bird (1868-1921), a distant cousin of Alexander Noble and the granddaughter of Robert Noble's brother, Thomas Noble (1824-1854). In 1882, Slingsby immigrated to Canada from Carlisle, England, with his grandparents, initially settling in Toronto before moving to Norval in 1886. Upon his arrival in Norval, Slingsby worked for John and Henry Pettigrew at the woollen mill, however by 1891, he was working as a farmer. By 1911, he was employed at Robert Noble's Grist Mill and had moved to the subject property. After Mary's death in 1921, John Slingsby continued to live on the subject property, and on December 8, 1925, John Slingsby purchased the subject property from Alexander Noble, after having rented it for over a decade.

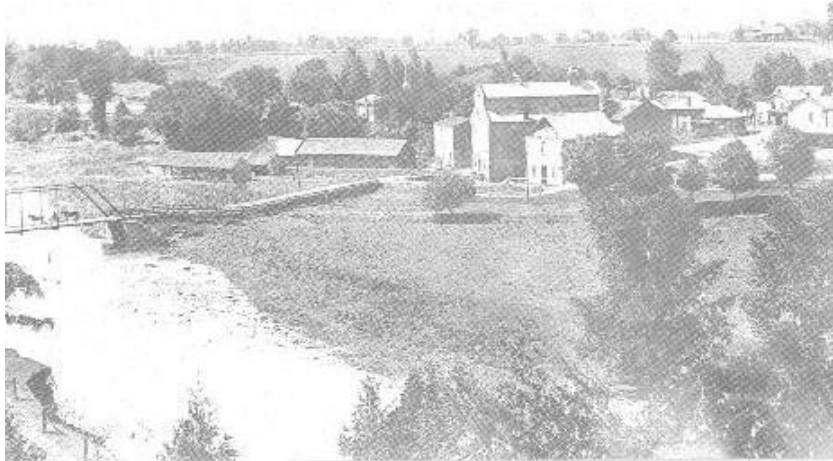

Figure 11: A view of Noble's Grist Mill C.1910 (EHS p10194f)

Following the purchase of the property in 1925, Slingsby continued to rent the adjoining unit to Mary's sister, Margaret "Maggie" Ellen Bird (1876-1958). A hand-drawn map of Norval from the early twentieth century identifies the subject shop property as the home of Maggie Bird and John Slingsby. The 1931 census lists Slingsby as a retired widower. Maggie Bird moved to Guelph in the 1940s, where she would live until her death in 1958.

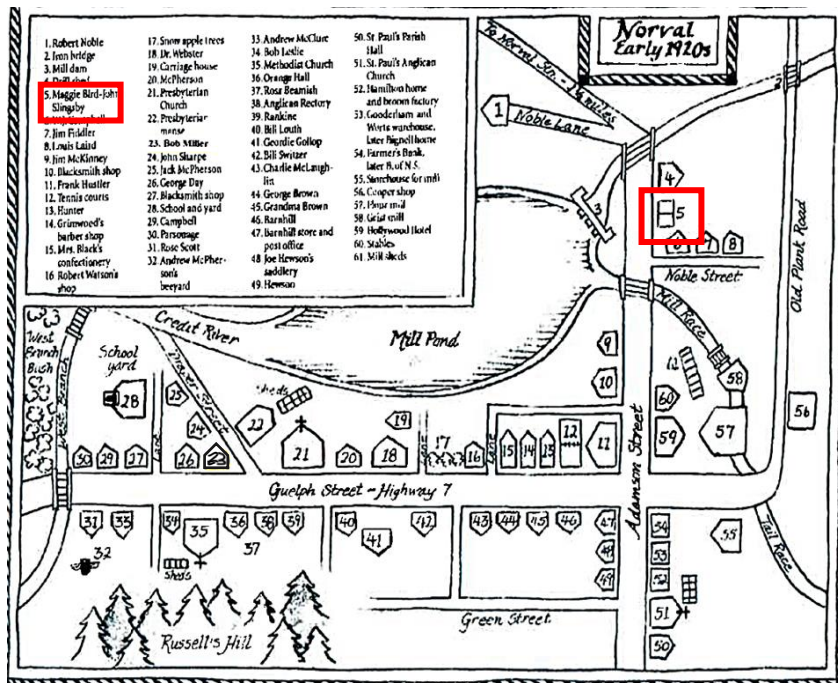

Figure 12: Village Map of Norval c. 1920, subject property identified in red. Inhabitants of subject property are identified as Maggie Bird and John Slingsby (EHS ON0098 MG1 A9)

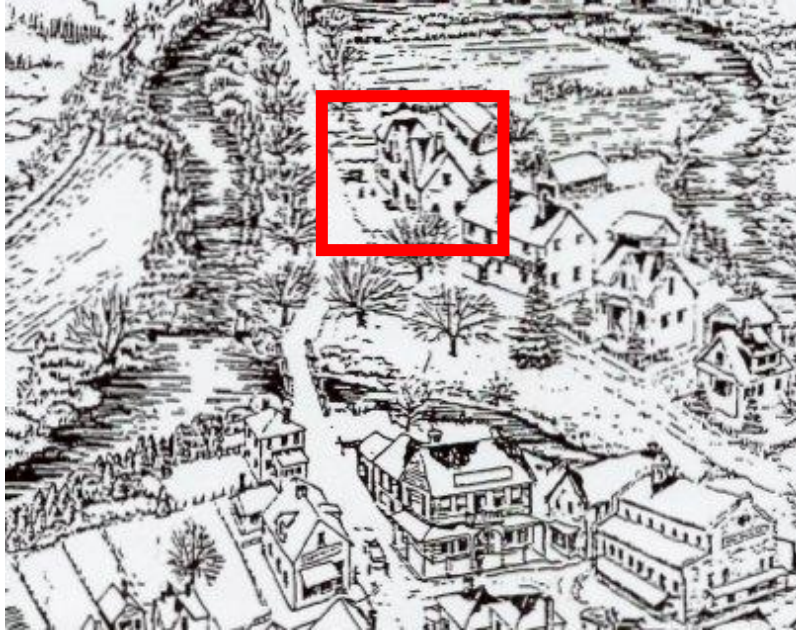

Figure 13: Subject property identified on the 1926 Birds Eye View of Norval (Artist's Impression) (MG12 A2.05)

The Pomeroy Family

Following Maggie Bird's departure, Ray Vincent Pomeroy and Clara Louise Pomeroy began renting the adjoining unit from John William Slingsby. On May 1, 1950, the Pomeroy family purchased the property from Slingsby. Slingsby continued to rent his unit until 1952, at which point he moved into the Halton Manor Retirement Home, remaining there until his death in 1959.

Ray Vincent Pomeroy (1907-1986) and Clara Louisa Pomeroy (née Bignell) (1908-1986) owned the subject property from 1950 to 1969. They had married in 1929 and had three children: William, Peter, and Marion. In 1954, their eldest son, William Morgan Pomeroy, and his wife, Marjorie Joan Pomeroy (née Cascadd), began occupying the adjoining unit previously inhabited by John William Slingsby.

Ray Pomeroy, Mill Manager for Georgetown Provincial Paper Ltd, was active in the community, coaching the Norval Monarchs softball team during the 1940s and 1950s. As a boating enthusiast, Ray was drawn to the property's proximity to the Credit River and began building and repairing boats in the early 1950s. By 1952, he had constructed a workshop on the property for this side business at the property now known 16 Adamson Street North.



Figure 14: Subject property identified in 1952 ortho-imagery; note the newly completed boat works. (Town of Halton Hills, 2024)

In October 1954, Hurricane Hazel caused substantial damage to the subject property. Moreover, one of the mill dams on the Credit River, located in front of the Pomeroy dwelling, was severely damaged, rendering the river unnavigable and causing frequent flooding downstream. After petitioning the town to repair the dam for two years without success, the Pomeroy's purchased it themselves. With the help of Norval residents, they repaired the dam and replaced its gates. These efforts were reported in the *Georgetown Herald* on October 31, 1956, bringing considerable attention to Pomeroy's boat works.

In 1956, Ray and William Pomeroy officially opened The Credit River Boat Company, specializing in boat repair. They also built and sold wooden boats until 1964 when they transitioned to fiberglass models. In the winter of 1958, the boat workshop on the property was destroyed by a fire. Ray wrote a letter to the fire department on January 29, 1958, praising their hard work and expressing his gratitude for saving both his and William's homes. The boat works were rebuilt in the 1960s.

By 1963, Ray Pomeroy had constructed another house on the property (now 18 Adamson Street North). The Credit River Boat Company was located between this new house and the residence at 12 & 14 Adamson Street North. The 1963 voter lists indicate that Ray, William, and Peter, along with their respective families, occupied these residences.

By 1965, William made the boating business his full-time job, repairing, making, and selling boats across Canada, operating out of 16 Adamson Street North. By 1990, the business was selling over 100 boats per year. Between 1967 and 1970, Ray and Clara retired and moved to Gore's Landing, Ontario.

In 1971, another fire destroyed the Credit River Boat Company, leading William to rebuild a larger and more modern boatworks at 16 Adamson Street North. In 1975, Judith Lee Pomeroy and Peter Pomeroy purchased the subject property from Ray and Clara Pomeroy. By this time, William was the owner of the residence at 18 Adamson Street North.

PT LT 11, CON 11 ESQ, AS IN 699558; EXCEPT PTS 1 AND 3 PL 20R20891; S/T 341253; S/T & T/W 415289; HALTON HILLS/ESQUESING



Figure 15: A photograph of Bill Pomeroy's Credit River Boat Co. in 1989(*Georgetown Herald*, April 26, 1989, p. 50)



Figure 16: An advertisement for Bill Pomeroy's Credit River Boat Company (*Acton Free Press*, March 21, 1979, p. 9)

During this time, Peter and Judith Pomeroy lived on the subject property. Judith was an active member of the Norval United Church. Peter owned North Halton Sports and Pete Pomeroy Sports in the 1970s, coached hockey, was elected Ward 3 Councilor in 1976 and as Mayor in 1978, and served as Regional Chair for Halton from 1983 to 1994. Pomeroy remains active in the Halton Hills community and was honoured at the 2024 Mayor's Levee. In 2018, Peter Pomeroy sold the subject property to its current owner.



Figure 17: Portrait of the 1982 Halton Hills Council. Peter Pomeroy was Mayor (seated at desk). (EHS 00380).



Figure 18: Portrait of Peter Pomeroy, Chairman of Halton Regional Council in 1990 (EHS 16875)

PT LT 11, CON 11 ESQ, AS IN 699558; EXCEPT PTS 1 AND 3 PL 20R20891; S/T 341253; S/T & T/W 415289; HALTON HILLS/ESQUESING



Figure 19: Subject property identified in 2002 aerial photography



Figure 20: Subject property identified in 2011 aerial photography

2.2 Property & Architectural Description

The subject property is located at 12 and 14 Adamson Street North in Halton Hills and is on the east side of Adamson Street North, parallel to the Credit River. The dwelling is set back nine meters from the road and is accessible from a driveway off Adamson Street. The existing building is a one and-a-half storey Gothic revival duplex constructed around 1869. The property is legally known as PT LT 11, CON 11 ESQ, AS IN 699558; EXCEPT PTS 1 AND 3 PL 20R20891; S/T 341253; S/T & T/W 415289; HALTON HILLS/ESQUESING.



Figure 21: Subject Property identified in 2023 aerial photography

PT LT 11, CON 11 ESQ, AS IN 699558; EXCEPT PTS 1 AND 3 PL 20R20891; S/T 341253; S/T & T/W 415289; HALTON HILLS/ESQUESING



Figure 22: Looking South down Adamson Street North from Subject Property (Google Street View 2024)



Figure 23: Looking North up Adamson Street North from Subject Property (Google Street View 2024)



Figure 24: Front (west) elevation of the existing building at 12 & 14 Adamson Street North (Town of Halton Hills 2024)

The front elevation of this duplex exemplifies a vernacular interpretation of Gothic Revival architecture, common in the mid- to late-nineteenth century in Ontario. The existing, rectangular-plan building features a symmetrically organized façade, and the steeply pitched roof features two prominent front-

PT LT 11, CON 11 ESQ, AS IN 699558; EXCEPT PTS 1 AND 3 PL 20R20891; S/T 341253; S/T & T/W 415289; HALTON HILLS/ESQUESING

facing gables, each topped with a wooden finial. The gable peaks feature decorative wooden bargeboard and small rectangular window openings (likely modified from lancet-arched openings).

A contemporary porch extends across the width of the front elevation, supported by simple wooden columns and featuring a flat roofline, which contrasts with the steeply pitched main roof. The duplex features two symmetrically placed entrances, each centered under a gable. Each entrance is flanked by a tall rectangular flatheaded window opening on either side. The façade currently features contemporary stucco.



Figure 25: Side (south) elevation of the existing building at 12 & 14 Adamson Street North (Town of Halton Hills 2024)

The side (south) elevation includes two vertically arranged windows set within tall flat-headed window openings on each floor. These windows are positioned beneath the gable end. The modest and unadorned eaves reflect the restrained approach often found in vernacular interpretations of the Gothic style, where excessive decoration is minimized in favor of simplicity and utilitarian function. The wall surface is finished with smooth modern stucco. A contemporary addition is extant at the rear of the existing building, finished with the same cladding as the rest of the building.



Figure 26: Side (north) elevation of the existing building at 12 & 14 Adamson Street North (Town of Halton Hills 2024)

The north (side) elevation of the duplex follows the design of the south side elevation. This elevation contains two vertically aligned, symmetrically placed windows on each floor, both set within tall rectangular flat-headed window openings positioned beneath the gable end, maintaining the building's symmetrical design.

The roofline of the main structure is steeply pitched, typical of the Gothic Revival style, while the eaves are modest and unadorned (apart from the front gable peaks).

Adjacent to the main structure is a modern addition with a lower roofline and a simpler design. This addition includes a single tall, narrow window facing west, and an exterior light fixture. A chimney is extant above the roof line at the rear of the modern addition.

2.2 Architectural Style & Comparative Analysis

The Gothic Revival architectural style, popular in Ontario from the mid-nineteenth century through the early-twentieth century, draws inspiration from medieval Gothic architecture. This style is characterized by its vertical emphasis, pointed arches, steeply pitched roofs, and ornate detailing, often implemented in rural and urban residential buildings. The Gothic Revival style became popular among settlers in Ontario as it evoked a sense of tradition and permanence, reflecting the growing prosperity and cultural aspirations of the time.

According to John Blumenson's *Ontario Architecture: A Guide to Styles and Building Terms, 1784 to the Present* typical features characteristic of the Gothic Revival style in Ontario include:

- Steeply pitched roofs, often with front-facing gables;
- Decorative bargeboards, adorning the eaves and gables;
- Tall, narrow windows, typically either arched or lancet;
- Use of finials and other ornamental elements to emphasize verticality;
- Chimneys placed symmetrically or near gable ends, contributing to the overall balance of the structure;
- Bay windows, often with pointed or arched tops; and,

- One-and-a-half storey design: Many Gothic Revival farmhouses in Ontario are built as one-and-a-half storey structures.

The duplex at 12 and 14 Adamson Street North is a representative example of the vernacular interpretation of the Gothic Revival style in Halton Hills, embodying many of the key characteristics that define the style. The one-and-a-half-storey structure is constructed on a rectangular plan, with a symmetrically organized façade that is mirrored across the two units. The steeply pitched roof features two prominent front-facing gables, each capped with a wooden finial and adorned with intricate wooden gingerbread trim.

The window openings on both the front and side elevations are tall and narrow, arranged symmetrically beneath the gables, further emphasizing the verticality of the design. The chimneys, which were originally positioned to the right of each respective gable, have since been removed.

The wide veranda that extends across the width of the façade is a later addition, postdating the original construction by several decades. While the veranda's flat roofline contrasts with the steeply pitched main roof, its simple fluted columns and understated design are sympathetic to the overall Gothic Revival aesthetic, maintaining the building's historical integrity.

In comparison to other Gothic Revival structures in Halton Hills, the duplex at 12 and 14 Adamson Street North stands out for its simplicity and restrained use of decorative elements, which is characteristic of vernacular interpretations of the style. While more elaborate Gothic Revival buildings in the area may feature pointed arches, stained glass, or more ornate detailing, this duplex embodies the essential elements of the style without excessive embellishment, a reflection of its utilitarian function as a workers' residence. The scale and function of the existing building on the subject property is comparable to the neighbouring residences at 12 & 14 Noble Street, also likely constructed for local working families in the 1860s. A Gothic Revival style duplex at the modern addresses of 128 & 130 Main Street South (Figure 28) in Georgetown, constructed around the same time as the residence on the subject property, exhibits several similar architectural features. These include dual front-facing gables, gable windows, and a comparable scale, form, and style.

PT LT 11, CON 11 ESQ, AS IN 699558; EXCEPT PTS 1 AND 3 PL 20R20891; S/T 341253; S/T & T/W 415289; HALTON HILLS/ESQUESING



Figure 27: c.1860s duplex at 12 and 14 Noble Street (Google Street View 2023)



Figure 28: c. 1870s Gothic Revival style duplex at the modern addresses of 128 & 130 Main Street South in Georgetown (Town of Halton Hills 2024)

The duplex at 12 and 14 Adamson Street North is also comparable to other Gothic Revival-style buildings within Norval, such as the residences at 10 Noble Street (Figure 29) and 484 Guelph Street (Figure 30). These buildings share a similar emphasis on verticality, symmetry, and the use of steeply pitched roofs and front-facing gables, though they vary in their level of ornamentation and the complexity of their design. The subject property, with its smooth stucco finish and minimal detailing, represents a more modest and utilitarian approach to the Gothic Revival style, reflecting the practical needs and aesthetic preferences of the time.



Figure 29: 10 Noble Street, Norval (Town of Halton Hills 2024)



Figure 30: 484 Guelph Street, Norval (Google Street View 2023)

Overall, the Gothic Revival duplex at 12 and 14 Adamson Street North is a significant example of the Gothic Revival style in Halton Hills, contributing to the architectural diversity of the area while offering a glimpse into the historical development of the region during the late 19th century. Its architectural features and historical context make it a valuable asset to the heritage of Halton Hills.

3.0 Description of Heritage Attributes and Evaluation Checklist

The following evaluation checklist applies to Ontario Regulation 9/06 made under the *Ontario Heritage Act*: Criteria for Determining Cultural Heritage Value or Interest. The criteria are prescribed for municipal designation of Heritage Properties under Part IV, Section 29 of the *Ontario Heritage Act*. The evaluation tables utilize an 'X' to signify applicable criteria and 'N/A' to signify criteria that are not applicable for this property.

Design or Physical Value	
Is rare, unique, representative, or early example of a style, type, expression, material, or construction method	X
Displays a high degree of craftsmanship or artistic merit	N/A
Demonstrates a high degree of technical or scientific achievement	N/A

The property at 12 & 14 Adamson Street North has physical and design value as a representative example of a Vernacular Gothic Revival Style duplex, within the community of Norval. The residence displays many of the key characteristics that define the Gothic revival style including its scale, form, and massing exemplified by its one-and-a-half-storey construction on a rectangular plan, with a symmetrically organized façade mirrored across the two units. The steeply pitched roof features two prominent front-facing gables, each capped with a wooden finial and adorned with wooden gingerbread trim. While the building has been slightly modified over 150 years, the original style, form, and principles remain observable in the modern structure.

Historical or Associative Value	
Has direct associations with a theme, event, belief, person, activity, organization, or institution that is significant to a community	X
Yields, or has potential to yield, information that contributes to an understanding of a community or culture	N/A
Demonstrates or reflects the work or ideas of an architect, artist, builder, designer, or theorist who is significant to a community	N/A

The property at 12 & 14 Adamson Street North has historical and associative value as it is directly associated with some of Norval's most prominent residents. Robert Noble, a key figure in the local flour milling industry, developed the nearby mills, which were instrumental in driving Norval's economy and early communal development. His son, Alexander Laing Noble, further modernized the mills, expanding their reach on a national scale. The subject property's connection to mill workers' housing further emphasizes its relationship to the area's industrial heritage and its significance in Norval's social and economic development.

The Pomeroy family, including Roy, William, and Peter Pomeroy, were active and respected members of the Norval community. William and Roy founded the Credit River Boat Company, a vital part of Norval's industrial history, while Peter Pomeroy, later the Mayor of Halton Hills, played a central role in local governance and community initiatives. The property's association with the Mills and the associated worker accommodations also contributes to an understanding of the community and culture of Norval.

Contextual Value	
Is important in defining, maintaining, or supporting the character of an area	X
Is physically, functionally, visually, or historically linked to its surroundings	X
Is a landmark	N/A

The property at 12 & 14 Adamson Street North holds significant contextual value, contributing to the preservation and definition of the late-nineteenth-century character of the area within the community of Norval. Located near the corner of Adamson Street North and Noble Street, and directly across from the mill dam on the Credit River, the dwelling on the subject property is physically, functionally, visually, and historically linked to its surroundings. The existing building is important in defining and maintaining the character of the area as one of the few workers' residences built to house the families of labourers at the Norval Mills. The extant residence is directly connected to the house immediately south of the subject property, at 12 & 14 Noble Street, a c.1850s dual workers' residence featuring Italianate influences; as well as Robert Noble's 1869 Gothic Revival home east of the subject property. Each of these houses has a direct association with the mills, the Noble family, and the broader Norval community. Like many of the surrounding properties, the dwelling on the subject property maintains much of its original Gothic Revival designs including the finials, bargeboards, gables, and porch detailing.

4.0 Summary

Following research and evaluation according to Ontario Regulation 9/06, it has been determined that the property at 12 and 14 Adamson Street North possesses physical and design value as a representative example of the Gothic Revival style, historical and associative value as a significant part of the architectural development of Halton Hills, and contextual value for its contribution to the streetscape along Adamson Street. The heritage attributes of the property are identified as follows:

- The setback, location, and orientation of the existing building within the subject property on the east side of Adamson Street North, parallel to the Credit River;
- The scale, form, and massing of the existing c.1870, one-and-a-half storey Gothic Revival residential building with a gable roof and stone foundation;
- The symmetrical organization of the façade;
- The front (west) elevation, including:
 - The steeply pitched cross-gable roof with two prominent front-facing gables,
 - Wooden finials and decorative wooden bargeboard;
 - Flat-headed window opening beneath the gables;
 - Centrally aligned entrances beneath the gable peaks;
 - Four flatheaded window openings on first floor, each flanking an entrance; and,
- The side (south and north) elevations, including:
 - The steeply pitched gable ends.

The rear (east) elevation and interiors have not been identified as heritage attributes as part of this report.

PT LT 11, CON 11 ESQ, AS IN 699558; EXCEPT PTS 1 AND 3 PL 20R20891; S/T 341253; S/T & T/W 415289; HALTON HILLS/ESQUESING

5.0 Sources

Primary Sources

"Abandoned Norval Flour Mill." *Esquesing Historical Society*, 1961.

Birds Eye View Map of Norval (Artist's Impression), 1926.

McNabb, James. "Military, Mill and Rank details." British Military and Naval Records (RG 8, C Series). *Collections Canada*. p. 5.

Upper Canada Land Petitions, Volume: 411; Bundle: P 1; Petition: 57; Microfilm:C-2733; Reference: RG 1 L3; 938.

Upper Canada Land Petitions, Page 827, vol 341A, bundle M12, petition 282, microfilm 2201.

Census Records

Census of Canada, 1891. Year: 1891; Census Place: Esquesing, Halton, Ontario, Canada; Roll: T-6340; Family No: 75.

Census of Canada, 1901. Year: 1901; Census Place: Esquesing, Halton, Ontario; Page: 1; Family No: 3.

Census of Canada, 1931. Library and Archives Canada; Ottawa, Ontario, Canada; Seventh Census of Canada, 1931; Folder Number: T-27267; Census Place: Halton, Ontario, Canada; Page Number: 6.

Census of England, 1871. The National Archives; Kew, London, England; 1871 England Census; Class: RG10; Piece: 5220; Folio: 119; Page: 27; GSU roll: 847439.

Land Records

Lot 11, Concession 11. Ontario Land Records Office. Accessed 2024.

Voter Lists

Library and Archives Canada; Ottawa, Ontario, Canada; Voters Lists, Federal Elections, 1935-1980.

Newspapers

"15 Years Ago." *Georgetown Herald* (Georgetown, ON), August 6, 1986, p. 4.

[Georgetown Herald \(Georgetown, ON\), August 6, 1986, p. 4: Halton Hills Newspapers \(vitacollections.ca\)](https://www.vitacollections.ca/Georgetown-Herald-Georgetown-ON-August-6-1986-p-4-Halton-Hills-Newspapers)

"Credit River Boat Co. Has Flourished in Norval since 1956." *Georgetown Herald* (Georgetown, ON), April 26, 1989, p. 50.

[Georgetown Herald \(Georgetown, ON\), April 26, 1989, p. 50: Halton Hills Newspapers \(vitacollections.ca\)](https://www.vitacollections.ca/Georgetown-Herald-Georgetown-ON-April-26-1989-p-50-Halton-Hills-Newspapers)

“Credit River Boat Co.” Acton Free Press (Acton, ON), March 21, 1979, p. 9.

[Georgetown Herald \(Georgetown, ON\), March 21, 1979, p. 33: Halton Hills Newspapers \(vitacollections.ca\)](#)

“Deaths: Bird.” Georgetown Herald (Georgetown, ON), August 6, 1958, p. 7.

[Georgetown Herald \(Georgetown, ON\), August 5, 1959, p. 7: Halton Hills Newspapers \(vitacollections.ca\)](#)

“Fireman Receive Praise for Good Work.” Georgetown Herald (Georgetown, ON), January 29, 1958, p. 5.

[Georgetown Herald \(Georgetown, ON\), January 15, 1958: Halton Hills Newspapers \(vitacollections.ca\)](#)

“Going Fishing?” Georgetown Herald (Georgetown, ON), July 2, 1952, p. 4.

<https://vitacollections.ca/HaltonHillsNews/91105/page/4?n=>

“Local News.” Georgetown Herald (Georgetown, ON), October 31, 1956, p. 14.

<https://vitacollections.ca/HaltonHillsNews/91341/page/14?n=>

“Margaret Ellen Bird.” Georgetown Herald (Georgetown, ON), August 13, 1958, p. 6.

[Georgetown Herald \(Georgetown, ON\), August 13, 1958, p. 6: Halton Hills Newspapers \(vitacollections.ca\)](#)

“Norval Boat Company.” Georgetown Herald (Georgetown, ON), August 5, 1971, p. 1.

<https://vitacollections.ca/HaltonHillsNews/2315209/page/1?q=Norval+Boat+Company&docid=OOI.2315209>

“Norval Man Angered By Parking.” Georgetown Herald (Georgetown, ON), May 7, 1986, p. 19.

[Georgetown Herald \(Georgetown, ON\), May 7, 1986: Halton Hills Newspapers \(vitacollections.ca\)](#)

“Obituary: Mrs. John Slingsby.” Georgetown Herald (Georgetown, ON), November 23, 1921, p.1.

<https://vitacollections.ca/HaltonHillsNews/89542/page/1>

“Pomeroy Cascadd in Norval United.” Georgetown Herald (Georgetown, ON), July 30, 1952, p. 5.

<https://vitacollections.ca/HaltonHillsNews/91109/page/5?n=>

“Pomeroy, Clara.” Georgetown Herald (Georgetown, ON), March 19, 1986, p. 18.

[Georgetown Herald \(Georgetown, ON\), March 19, 1986, p. 18: Halton Hills Newspapers \(vitacollections.ca\)](#)

“Ray Pomeroy Engagement.” Georgetown Herald (Georgetown, ON), March 20, 1929, p. 3.

PT LT 11, CON 11 ESQ, AS IN 699558; EXCEPT PTS 1 AND 3 PL 20R20891; S/T 341253; S/T & T/W 415289; HALTON HILLS/ESQUESING

[Georgetown Herald \(Georgetown, ON\), March 20, 1929, p. 3: Halton Hills Newspapers \(vitacollections.ca\)](#)

“Ray Pomeroy Named Mill Office Manager.” Georgetown Herald (Georgetown, ON), August 18, 1954, p. 1.

[Georgetown Herald \(Georgetown, ON\), August 18, 1954, p. 1: Halton Hills Newspapers \(vitacollections.ca\)](#)

“Resident 70 Years in Norval and District.” Georgetown Herald (Georgetown, ON), April 29, 1959, p. 8.

[Georgetown Herald \(Georgetown, ON\), April 29, 1959: Halton Hills Newspapers \(vitacollections.ca\)](#)

“Pomeroy Wins in Landslide.” Acton Free Press (Acton, ON), November 15, 1978, p. 1.

[Acton Free Press \(Acton, ON\), November 15, 1978, p. 1: Halton Hills Newspapers \(vitacollections.ca\)](#)

Vital Records

Archives of Ontario; Toronto, Ontario, Canada; Registrations of Marriages, 1869-1928; Reel: 74.

Archives of Ontario; Toronto, Ontario, Canada; Series: Registrations of Births and Stillbirths, 1869-1913; Reel: 187; Record Group: Rg 80-2.

Secondary Sources

Ancestry.com. Canada, Find a Grave® Index, 1600s-Current [database on-line]. Lehi, UT, USA: Ancestry.com Operations, Inc., 2012.

Blumenson, John. Ontario Architecture: A Guide to Styles and Building Terms 1784 to the Present. Canada: Fitzhenry & Whiteside, 1990.

Carter, J.B. Norval History, 1820-1950, 2006.

Canadian Headstones; Canada; Canadian Headstone Photo Project.

Hollywood Hotel & Flour Mill. 1900. Esquesing Historical Society. EHS10187.

“Mayor’s levee a night of pomp, circumstance and history.” 2024. Accessed from Halton Hills Today: <https://www.haltonhillstoday.ca/local-news/mayors-levee-a-night-of-pomp-circumstance-and-history-8095102>.

McDonald, J. Halton Sketches Revisited. Norval: Dills Printing and Publishing Company Limited, 1996.

McDonald, J. Halton Sketches. Acton: Dills Printing and Publishing, 1976.

Pope, J.H. Illustrated Historical Atlas of the County of Halton. Toronto, 1877.

PT LT 11, CON 11 ESQ, AS IN 699558; EXCEPT PTS 1 AND 3 PL 20R20891; S/T 341253; S/T & T/W 415289; HALTON HILLS/ESQUESING

“Robert Noble and Heirs Played Prominent Part in Norval History.” In McDonald, J. Halton Sketches. Acton: Dills Printing and Publishing, 1976.

Research and Evaluation Report



(Town of Halton Hills 2024)

Frances Williams House

15 Mountain Street, Glen Williams, Town of Halton Hills

October 2024

Project Personnel

Report Authors

Austin Foster, MA
Cultural Heritage Assistant

with

Laura Loney, MPlan, MCIP, CAHP, RPP
Manager of Heritage Planning

Historical Research

Austin Foster

Laura Loney

Field Review

Austin Foster

Laura Loney

Report Preparation

Austin Foster

Laura Loney

Mapping Graphics:

Rehan Waheed, MA
Planning Data Analyst

Report Reviewers:

Caylee MacPherson
Planner – Development Review & Heritage

Bronwyn Parker
Director of Planning Policy

John Linhardt
Commissioner of Planning & Development

Table of Contents

1.0 Property Description..... 5

2.0 Background 5

 2.1 Historical Background 6

 2.2 Property & Architectural Description 15

 2.3 Architectural Style & Analysis..... 18

3.0 Description of Heritage Attributes and Evaluation Checklist..... 20

4.0 Summary 21

5.0 Sources..... 23

Table of Figures

Figure 1: Location Map - 15 Mountain Street..... 5

Figure 2: Aerial Photograph - 15 Mountain Street 5

Figure 3: Subject property identified on the 1822 Patent Plan 7

Figure 4: Subject property identified on the 1819 Patent Plan 7

Figure 5: Glen Williams Village Plan (1877 *Illustrated Historical Atlas of the County of Halton*)..... 8

Figure 6: Subject property identified on the 1877 *Illustrated Historical Atlas of the County of Halton* 9

Figure 7: Subject property identified on the 1909 National Topographic Survey 10

Figure 8: A photograph of the Thompson family at 548 Main St. showing Isabella Thompson (in black), Catherine and Mary Thompson and Eva Thompson. C. 1915. (EHS 19926) 11

Figure 9: A 1956 photograph of the c.1920s-1930s rear addition constructed by the Thompson family (Courtesy of Christine Earl, 2024) 11

Figure 10: Earl and Frost’s diagram for their VTOL Design. U.S Patent Office, John C. M. Frost. Vertical Take Off and Landing Apparatus designed in May 1955. 12

Figure 11: Northeast elevation of 15 Mountain Street in 1961 (Courtesy of Christine Earl 2024)..... 12

Figure 12: Marjorie and children at the rear of the residence on the subject property c.1960s (Courtesy of the Earl family, 2024) 13

Figure 13: An Earl family tennis match and the southwest elevation of 15 Mountain Street c.1960s (Courtesy of Christine Earl 2024) 13

Figure 14: Georgetown and District High School Wrestlers: Doug Hilts & Tim Bragg-Smith. February 18, 1965 (EHS p8121f) 13

Figure 15: Georgetown District High School Wrestling Team in 1965 (EHS p8127f) 13

Figure 16: Subject property identified in 1960 aerial photography 14

Figure 17: Composite photo of the Avian 2-180 flying over Lincoln Motors (Baz Motors). April 26, 1962 (EHS 08650)..... 14

Figure 18: Subject Property identified on 1942 National Topographical Survey 14

Figure 19: Subject Property identified on 1974 National Topographical Survey 14

Figure 20: Subject property identified in 2023 aerial photography 15

Figure 21: Front (northwest) elevation of the existing building at the subject property (Town of Halton Hills 2024) 15

Figure 22: Side (northeast) elevation of the existing residence on the subject property (Town of Halton Hills 2024) 16

Figure 23: Side (southwest) elevation of the existing building at the subject property, slightly obscured by mature tree (Town of Halton Hills 2024) 17

Figure 24: Side (southwest) elevation of the existing building at the subject property (Town of Halton Hills 2024) 17

Figure 25: Looking northeast up Mountain Street from subject property (Town of Halton Hills 2024) 17

Figure 26: Looking southwest down Mountain Street from subject property (Town of Halton Hills 2024) 17

Figure 27: View of the Credit River Valley looking southeast from the subject property (Town of Halton Hills 2024) 18

Figure 28: View of the Credit River Valley looking southeast from the subject property (Town of Halton Hills 2024) 18

Figure 29: Contemporary addition to rear of 15 Mountain Street (Town of Halton Hills 2024) 18

Figure 30: A Georgian Residence at 504 Main Street, Glen Williams. (Town of Halton Hills 2024) 19

Figure 31: A Georgian Residence at 510 Main Street, Glen Williams. (Google Street View 2023)..... 19

1.0 Property Description

15 Mountain Street, Glen Williams	
Municipality	Town of Halton Hills
County or Region	Regional Municipality of Halton
Legal Description	LT 39, RCP 1556; HALTON HILLS
Construction Date	c.1854
Original Use	Residential
Current Use	Residential
Architect/Building/Designer	Charles Williams
Architectural Style	Georgian
Additions/Alterations	Late nineteenth century addition to the rear; early twentieth century addition to the rear; and contemporary addition to rear
Heritage Status	Listed on the Town’s Heritage Register
Recorder(s)	Austin Foster; Laura Loney
Report Date	October 2024

2.0 Background

This research and evaluation report describes the history, context, and physical characteristics of the property at 15 Mountain Street in Glen Williams in the Town of Halton Hills. The report includes an evaluation of the property’s cultural heritage value as prescribed by the *Ontario Heritage Act*.



Figure 1: Location Map - 15 Mountain Street

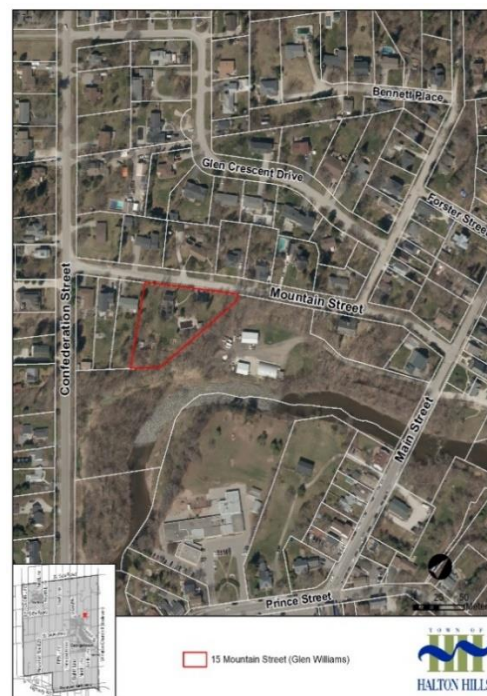

Figure 2: Aerial Photograph - 15 Mountain Street

2.1 Historical Background

Indigenous History Background

The enduring history of First Nation Peoples in Halton Hills can be traced back through time immemorial before contact with Europeans in the 1600s. Prior to the arrival of European settlers, the Credit River was central to Indigenous ways of life, supporting settlements, fisheries, horticulture, transportation, and trade. Iroquoian-speaking peoples, ancestors of the Wendat, occupied the Credit River Valley for hundreds of years until approximately the mid-1600s, establishing semi-permanent villages. There are numerous archaeological sites in Halton Hills dating from this period, ranging from village sites to burial grounds, which reveal a rich cultural heritage. The Wendat were displaced by the Haudenosaunee around 1649-50 amid the conflicts that arose between European colonial powers and their First Nation allies. The Mississaugas (part of the Anishinaabe Nation) arrived in southern Ontario in the 1690s, settling in two groups along the north shore of Lake Ontario and Lake Erie. The western group, occupying the area between Toronto and Lake Erie, became known as the Mississaugas of the Credit First Nation. Until the early nineteenth century, the Mississaugas of the Credit First Nation followed a seasonal cycle of movement and resource harvesting along the Credit River (Missinnihe, meaning "trusting creek"), and other rivers. In the winter months, extended family groups hunted in the Halton Hills area, travelling south towards the mouth of the river in the spring for the salmon run. The Mississaugas' fisheries and traditional economies were diminished as a result of increased Euro-colonial settlement, leading to a state of impoverishment and dramatic population decline.

In 1818, the British Crown negotiated the purchase of 648,000 acres of land from the Mississaugas of the Credit First Nation, including present-day Halton Hills, under the Ajetance Treaty (No. 19), named after Chief Ajetance. This left the Mississaugas with three small reserves on the Lake Ontario shoreline. The legitimacy of early land "surrenders" to the Crown is questionable when considering the Mississaugas' traditional understanding of property ownership. Unlike the British, the Mississaugas understood land in spiritual terms, and did not share the idea that access to land and resources could be given up permanently.

In 1986, the Mississaugas initiated a claim against the Government of Canada over the 1805 Toronto Purchase. On June 8, 2010, the parties involved reached a final compensatory agreement. It resulted in a cash payment of \$145 million to the Mississaugas of the Credit First Nation.¹

Early European Settlement and the Williams Family

In 1818, the Crown granted John Butler Muirhead (1796-1824), the son of a Loyalist family Lot 21, Concession 10 in Esquesing Township. He completed his settlement duties on his 200 acres on June 13, 1823. In May 1824, he married Ann Dockstader (1804-1837). The Crown patent for the land was issued to Muirhead on September 25, 1824, however he died suddenly on November 29 of that same year. Muirhead's heirs inherited the property and promptly sold it to Benajah Williams in 1825.



Figure 3: Subject property identified on the 1822 Patent Plan

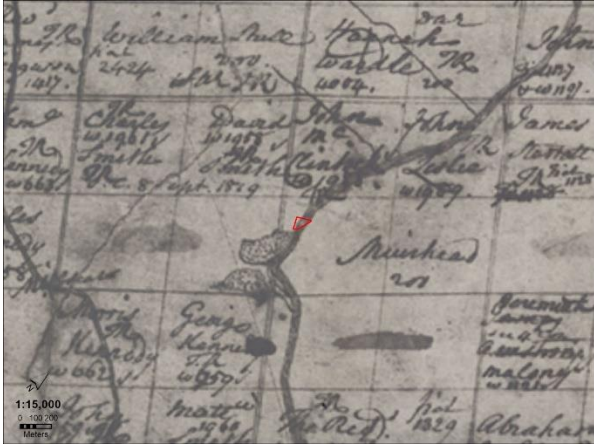

Figure 4: Subject property identified on the 1819 Patent Plan

Benajah Williams (1765-1851), a clothier from Gainsborough Township, Niagara, moved to Esquesing Township in the spring of 1825 with his third wife, Elizabeth Kennedy (1788-1842), and nine of his fifteen children: John Richard (1792-1858), Joel (1803-1871), Lydia (1809-1876), Charles (1811-1889), George (1813-1836), Jacob (1816-1853), Ira (1818-1833), Isaac (1820-1911), and David (1827-1902).

On October 12, 1824, Benajah listed his mill property and Grimsby Township property for sale in the *Niagara Gleaner*. He then purchased Lot 21, Concession 10, Esquesing Township from the heirs of John Butler Muirhead on November 9, 1825. At the age of 60, Benajah established a sawmill on Lot 21, working with his sons to dig a mill raceway, create a dam, and construct the mill within their first year on the land. After the sawmill's completion, the Williams family built a wooden grist flour mill along the Credit River.

The success of his milling industries enabled Benajah to purchase an adjoining 200 acres of land within Lot 21, Concession 9 in 1833, where he established the village of Williamsburg and built a crossroad to allow for more accessible transportation to the area. In the years following, Williams surveyed and severed small parcels of his land to his family. Benajah's son Charles established a general store, and in 1839 his son Jacob opened a woollen mill on the Credit River (below what is now Mountain Street). Son Joel Williams began farming Lot 21, Concession 10 in 1830.

Benajah's other sons established equally profitable trades in the area as blacksmiths, cabinetmakers, and later, leather tanners. Benajah formally divided his Williamsburg (later known as Glen Williams) property between his second and third sons. Charles received the south-easterly 106 acres on February 4, 1842, while Jacob received the north-westerly 94 acres on July 24, 1843, which included the woollen mill he had established in 1839. Following the division of the property, the brothers had a village plan drawn up.

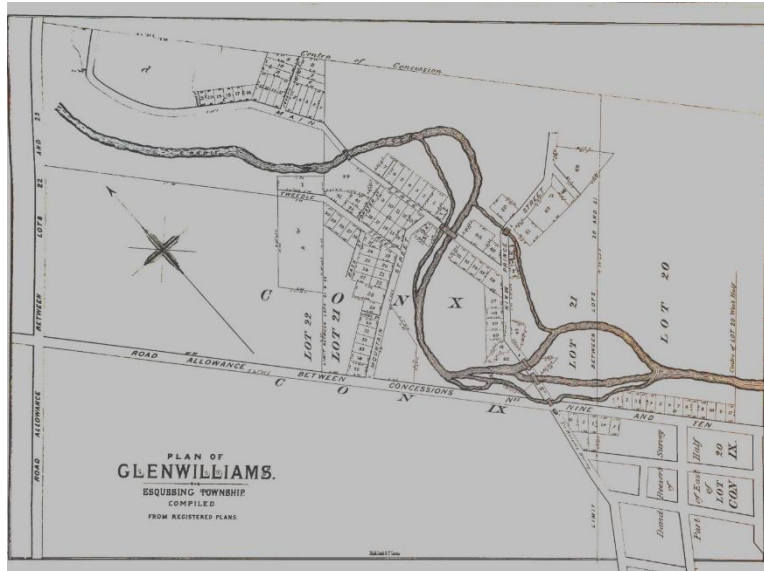

Figure 5: Glen Williams Village Plan (1877 *Illustrated Historical Atlas of the County of Halton*)

The settlement quickly attracted several industries. Besides Charles Williams' saw and flour mills, the woollen mills, and the tannery, there were cabinet makers, pump makers, shingle makers, Joseph Tweedle's and Archibald Cooper's sawmills, and Leslie's brickyards.

Jacob and Frances Williams

Jacob Williams (1816-1853) had established his sawmill on Lot 21, Concession 10 in 1839. Jacob was married to Frances Huestis (1822-1887), with whom he had five children: Catherine (1836-1908), Mary (1840-1843), Melissa (1841-1932), Frances Elizabeth (1848-1861), and Jacob Irvin (1852-1879). In 1849, Jacob built a Gothic Revival house on Village Lot 11 (now 548 Main Street) where the family lived for the next five years. Jacob died suddenly on July 12, 1853. In his will, he made provisions for his wife and children and ordered the sale of all his lands. His brother, Charles Williams (1811-1889), purchased the remainder of Jacob's estate, including the woollen mill and the house on Village Lot 11.

Following Jacob's death, the subject property, a western portion of Lot 21, Concession 10, was severed from the greater mill property and transferred to Jacob's widow, Frances Huestis Williams; Charles Williams served as the executor of the estate. Charles then constructed a six-room Georgian brick house on the subject property for Frances in 1854. The house overlooked the woollen mill and served as Frances' residence until 1875. After selling the property to the Georgetown hardware merchant Dugald Reid (1836-1903) in 1875, Frances moved to Toronto where she lived until her death at 46 Bismark Avenue in 1887.

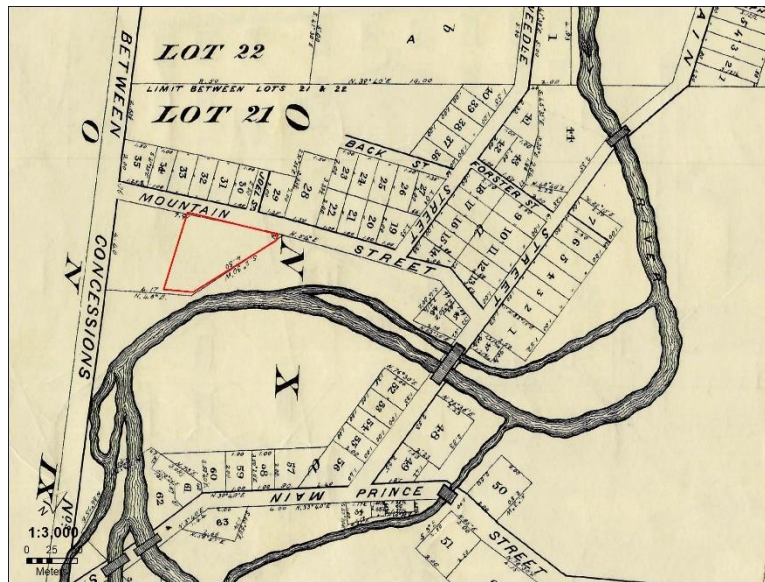

Figure 6: Subject property identified on the 1877 *Illustrated Historical Atlas of the County of Halton*

The Reid Family

Dugald Reid (1836-1903) emigrated from Glasgow to Esquesing Township with his parents in the mid-nineteenth century. By 1857, he was employed as a clerk in Georgetown. By 1861, Reid was working as a clerk and bookkeeper for James Young, a prominent local merchant. Reid was also listed as a sergeant in the Georgetown Volunteer Company during the 1866 Fenian Raids.

Dugald Reid married Janet McGill (1839-1917) around 1861, with whom he had six children: George Donald (1864-1948), Frank Dugald (1870-1903), Janet "Jessie" McGill (1874-1912), Laird Young (1876-1925), John Peter (1879-1949), and William Gilchrist (1880-1946). Reid established a hardware store in Georgetown in 1864 and expanded his business in 1879 by constructing a three-storey masonry building on Main Street on land purchased from James Young. During this period, Dugald Reid and his family lived in Georgetown at the modern address of 124 Main Street. In 1875, he purchased the subject property and rented it to various tenants, including his distant cousin, William Henry Reid, who would eventually purchase the property from Dugald and Janet in 1890.

William Henry Reid, son of James Henry Reid (1824-1900) and Elizabeth "Betsy" Hiltz Reid (1831-1903), was a stone mason in Georgetown and Glen Williams, as listed in the 1891, 1901, and 1911 censuses. He married Mary Elizabeth Stull (1863-1903) in 1887, and together they had five children: Mable Caroline (1888-1932), Lewis Henry "Lew" (1889-1957), Mary Elizabeth Anna "Mamie" (1891-1978), Elma Evelina (1893-1941), and Laura Gertrude (1899-1915). The couple raised their children on the subject property, and following Betsy's death in 1903, William lived in the home as a widower for the remainder of his life. After William's death in 1919, his daughter, Mary Elizabeth Graham (1891-1978), acted as the executor of his estate. Mary Elizabeth had married John Alderson Graham (1886-1938), and by 1921, they had settled in Norval with their son, John Reid Graham (1920-2006).

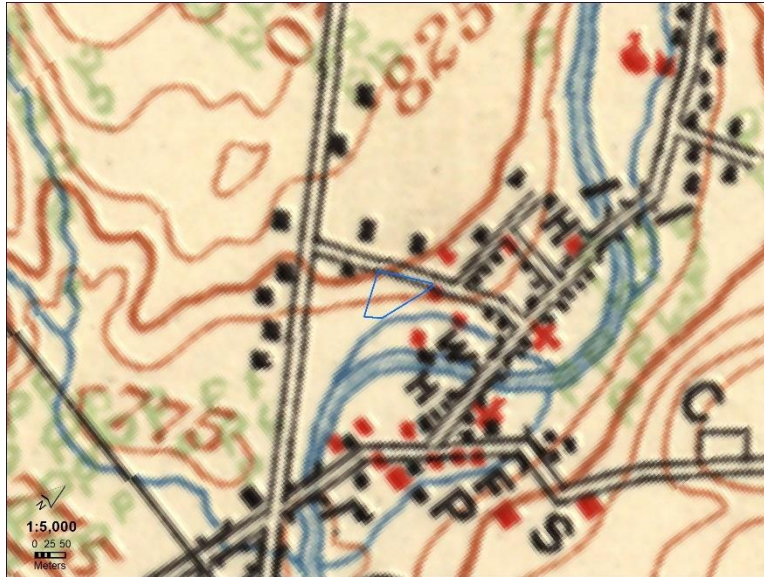

Figure 7: Subject property identified on the 1909 National Topographic Survey

The Thompson Family

Mary Elizabeth Graham sold the subject property in 1919 to Ernest G. Barraclough, who then sold it to Mary Thompson in the autumn of that year. Mary Thompson (1866-1947) and Catherine Thompson (1863-1928) were sisters born to James Thompson (1827-1897) and Isabella Shaw Thompson (1822-1920) in Glen Williams. The family lived at what is now 548 Main Street from 1880 until 1920. James Thompson was initially a millwright, as listed in the 1857 Canada Directory, and later a farm labourer according to the 1891 census, which also records his children's occupations as weaver, papermaker, dyer, knitter, and glove maker. Following James's death in 1897, the unmarried sisters remained at the family home with their mother, Isabella. Catherine is listed as a weaver and Mary as a knitter in the 1891 and 1901 censuses.

Following Isabella's death in 1920, Mary and Catherine sold their family home at 548 Main Street and moved to the subject property at 15 Mountain Street. Their brother, John "Jack" Alexander Thompson (1863-1941), and his daughter, Margaret Evelyn "Eva" Thompson, moved in with them. Jack had previously left his job as a paper maker to pursue business opportunities in the United States. While there, Jack learned a ginger beer recipe which he had pledged never to write down or pass on. He returned to the family home between 1912 and 1916 after the death of his wife, Eveyln "Eva" Allen, and established his ginger beer business from the subject property in 1921.



Figure 8: A photograph of the Thompson family at 548 Main St. showing Isabella Thompson (in black), Catherine and Mary Thompson and Eva Thompson. C. 1915. (EHS 19926)

Jack operated his ginger beer business, *Thompson & Wilson Beverage Company*, with his partner Jim Wilson, at the subject property until the end of Prohibition in 1927. Around this time, the Thompson family constructed an addition to the rear of the property, using the new cellar as a storeroom and constructing their workshop above it. The drink was brewed and bottled on the premises, and the company's ginger beer, "Green River," was sold at fairs across southern Ontario. The 1921 census describes the dwelling on the subject property as a 6-7 room house, with Jack listed as a brewer.



Figure 9: A 1956 photograph of the c.1920s-1930s rear addition constructed by the Thompson family (Courtesy of Christine Earl, 2024)

Catherine Thompson died in 1928. Jack continued to live on the subject property until his death in 1941. Mary Elizabeth Thompson sold the property to her niece Eva Thompson in 1943 but continued to live there until her death in 1947. Eva, who had moved to Toronto, rented the property to various tenants after Mary's death, including the Bragg-Smiths who would later purchase the property from the Earls in 1962 for \$17,500.

Modern Ownership

In 1956, Eva sold the subject property to Marjorie and Thomas Desmond Earl. The Earls immigrated to Canada around 1951 where they raised four children who attended school in Glen Williams. Thomas worked as an aerospace engineer and Marjorie managed their home. Thomas, an avid tennis player, constructed a tennis court on the southwest side on the subject property, while Marjorie kept large gardens around the property. By the 1950s, the residence's original wood-framed windows had been replaced, though the red-brick remained unpainted. A mature orchard was located at the rear of the property consisting of several stone fruit trees. Mature maple and chestnut trees framed the dwelling, and the property featured a wide array of honey locusts and perennial gardens.

On May 9, 1955, Thomas Earl, along with John Carver Meadows Frost, filed patent No. 507,099 for a Vertical Take-Off and Landing (VTOL) aircraft, which they had been developing since 1947. It was granted on February 6, 1962. Later that year, the couple sold the subject property to Arthur Bragg-Smith and moved to Malton, where Thomas was contracted by Avro Canada to work on the Blue Skies research project, contributing to the development of the Avro VZ-9 Avrocar. This VTOL aircraft was part of a secret U.S. military project in the early years of the Cold War.

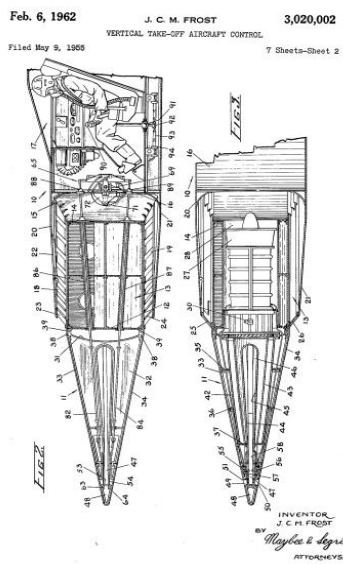

Figure 10: Earl and Frost's diagram for their VTOL Design. U.S Patent Office, John C. M. Frost. Vertical Take Off and Landing Apparatus designed in May 1955.



Figure 11: Northeast elevation of 15 Mountain Street in 1961 (Courtesy of Christine Earl 2024)



Figure 12: Marjorie and children at the rear of the residence on the subject property c.1960s (Courtesy of the Earl family, 2024)



Figure 13: An Earl family tennis match and the southwest elevation of 15 Mountain Street c.1960s (Courtesy of Christine Earl 2024)

Arthur Bragg-Smith was born in Kent, England, in 1909. He married Joyce Margaret in Warwickshire in 1947, and shortly after, the couple moved to Canada. In 1957, Arthur began working at Avro Canada. The Bragg-Smiths raised their three children—Susan, Timothy, and Rupert—on the subject property. During their time there, Timothy became Georgetown High School’s champion wrestler in 1965. Arthur worked as an aerospace engineer and Joyce managed their home.

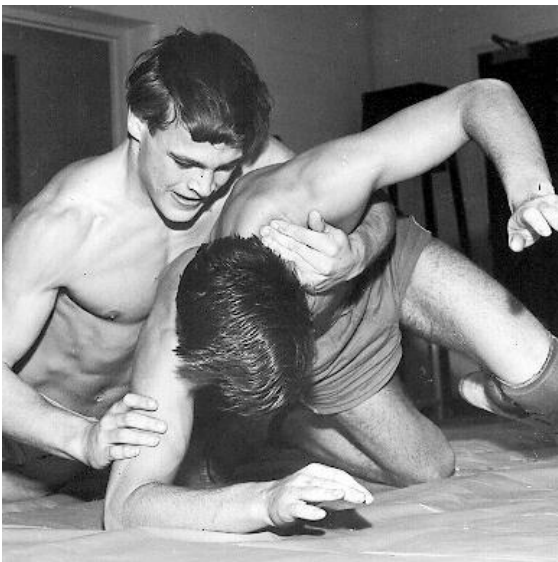

Figure 14: Georgetown and District High School Wrestlers: Doug Hilts & Tim Bragg-Smith. February 18, 1965 (EHS p8121f)

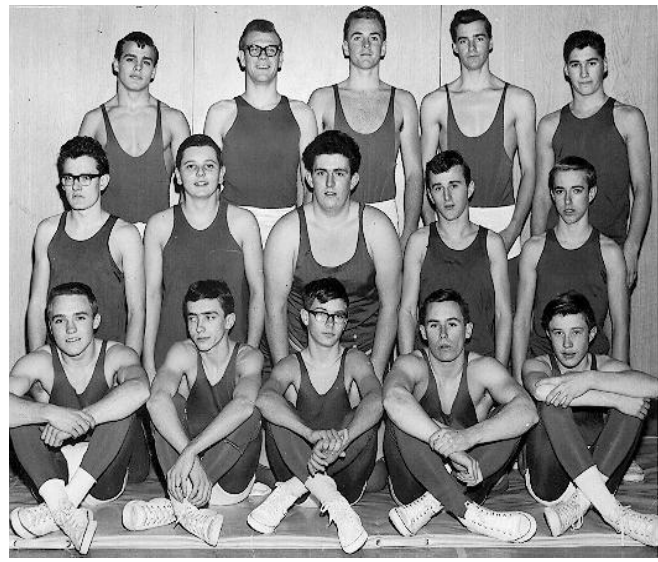

Figure 15: Georgetown District High School Wrestling Team in 1965 (EHS p8127f)

In 1959, Arthur was one of the former Avro Canada employees who formed Avian Aircraft Ltd. in Georgetown. Together with Peter Rowland Payne, Arthur designed a compound aircraft, the two-seat 2/180 Gyroplane. The prototype 2/180A CF-MTV-X flew in early 1960 but was seriously damaged in an accident due to a non-design fault. A second prototype, the 2/180B CF-NWS-X, incorporated several changes and successfully flew for the first time on February 16, 1961. In December 1964, Avian received

a \$540,000 Canadian government contract to build a modified Gyroplane, leading to full FAA certification in the 1970s.



Figure 16: Subject property identified in 1960 aerial photography



Figure 17: Composite photo of the Avian 2-180 flying over Lincoln Motors (Baz Motors). April 26, 1962 (EHS 08650)



Figure 18: Subject Property identified on 1942 National Topographical Survey



Figure 19: Subject Property identified on 1974 National Topographical Survey

Arthur and Joyce purchased the subject property from the Earls in 1962 and lived there until 1971, when they sold it to Jesse and Eloise-Anne Allan. The Bragg-Smith family then settled in Acton, where Joyce died in 1991, followed by Arthur in 1997 at the age of 88. The Allan's owned the property until 1987, when they sold it to the Goodfellow family, who sold it in 1993. The subject property was last sold in 2003 to its current owners.

2.2 Property & Architectural Description

The subject property is located at 15 Mountain Street along the northwest side of the Mountain Street in Glen Williams, Halton Hills and contains a two-story brick residential building and a one-story detached garage. The property is an irregularly shaped parcel that fronts Mountain Street and overlooks the Credit River in the rear. The dwelling is accessed via a driveway off Mountain Street. The property is legally known as LT 39, RCP 1556; HALTON HILLS.



Figure 20: Subject property identified in 2023 aerial photography



Figure 21: Front (northwest) elevation of the existing building at the subject property (Town of Halton Hills 2024)

The front (northwest) elevation facing Mountain Street is typical of Georgian Revival architecture, emphasizing symmetry and balance. The structure is constructed of brick laid in a common bond pattern and painted yellow. The original central entrance is framed by a pedimented portico supported by pilasters. The entrance is flanked by evenly spaced windows with graduated fenestration including larger, two-pane double-hung sash windows on the ground floor and smaller, single-pane windows on the upper floor. The ground floor windows feature simple lintels above and rest on painted limestone sills, with the upper floor windows also featuring stone sills. Each window is flanked by wooden shutters.

The original entrance has been infilled and now serves as a window. The pilasters, portico, and sidelight windows are period appropriate restorations installed in 2010. The shallow-pitched gable roof includes brick chimneys extending above the roofline on both sides and modest over-hanging eaves. The building rests on a raised stone foundation.



Figure 22: Side (northeast) elevation of the existing residence on the subject property (Town of Halton Hills 2024)

The side (northeast) elevation of the existing building is divided into two distinct sections. The front, northernmost section features a simple gable end with two evenly spaced, rectangular window openings with wooden shutters, currently featuring two-over-two double-hung sash windows at the first storey and one-over-one hung windows on the second storey. The window openings feature painted limestone sills and lintels. The eaves are modestly overhanging, and a brick chimney rises above the gable end, maintaining the symmetrical and restrained design typical of Georgian architecture.

The first storey of the rear, stepped-back portion of the elevation was likely constructed as a summer kitchen later in the nineteenth century, with brickwork and a stone foundation matching the original section of the house. In contrast, the second storey of this addition is a Gothic Revival inspired structure built in the late twentieth century. This section includes two gables, each featuring a central rectangular gable window. The upper floor is clad in board-and-batten siding, while the first floor features a flat-headed door opening with sidelights and a period-appropriate, sympathetic door replacement. A small square window with a stone sill is extant beside this entrance.



Figure 23: Side (southwest) elevation of the existing building at the subject property, slightly obscured by mature tree (Town of Halton Hills 2024)



Figure 24: Side (southwest) elevation of the existing building at the subject property (Town of Halton Hills 2024)

The side (southwest) elevation features a simple gable end with two evenly spaced rectangular window openings, each fitted with wooden shutters. The first storey has two-over-two double-hung sash windows, while the second storey features one-over-one hung windows. All window openings are accented with painted limestone sills and lintels. The eaves modestly overhang, and a brick chimney rises above the gable end. The stone foundation has been parged. The single-storey nineteenth-century addition, constructed with the same brick laid in a common bond pattern as the original residence, includes two narrow rectangular window openings with limestone sills and lintels, divided by a projecting chimney that extends above the roofline. A modern second storey addition featuring a cross gable roof and gable-peak window is built above the single storey addition.

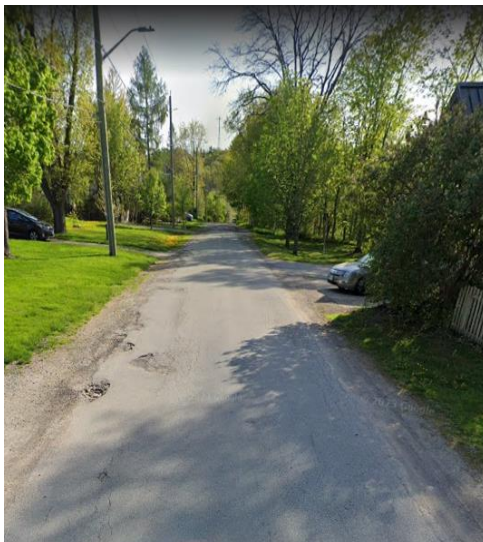

Figure 25: Looking northeast up Mountain Street from subject property (Town of Halton Hills 2024)



Figure 26: Looking southwest down Mountain Street from subject property (Town of Halton Hills 2024)



Figure 27: View of the Credit River Valley looking southeast from the subject property (Town of Halton Hills 2024)



Figure 28: View of the Credit River Valley looking southeast from the subject property (Town of Halton Hills 2024)



Figure 29: Contemporary addition to rear of 15 Mountain Street (Town of Halton Hills 2024)

2.3 Architectural Style & Analysis

Georgian residential architecture was prevalent in Ontario from the late-eighteenth century through the mid-nineteenth century, particularly between 1780 and 1860. This style, rooted in classical proportions and symmetry, was brought to Canada by British settlers and United Empire Loyalists, and became a dominant architectural expression in early colonial settlements.

According to John Blumenson's *Ontario Architecture: A Guide to Styles and Building Terms, 1784 to the Present* typical features characteristic of the Georgian style in Ontario include:

- Symmetrical Facades: The front elevation is highly symmetrical, often centered around a prominent entrance with neo-classical detailing;
- Hipped or Gabled Roofs: Georgian homes typically feature hipped roofs, though gabled roofs are also common;
- Graduated Fenestration: Windows are symmetrically arranged, with larger windows on the ground floor and smaller ones above, often featuring multi-paned sash windows;
- Brick or Stone Construction: Georgian homes are commonly constructed of brick or stone, with bricks often laid in a Flemish bond pattern;
- Classical Detailing: Features such as modillions under the eaves, limestone lintels above windows and doors, cornice with modillion blocks, moulded window surrounds, pedimented porticos; and,
- Chimneys: Symmetrically placed chimneys are a hallmark of Georgian architecture, often located at the center of side elevations.

The existing c.1854 building at 15 Mountain Street in Glen Williams can best be described as a Georgian-style residential structure, retaining key features typical of this architectural style. These include a symmetrical front elevation, graduated fenestration, a neo-classical pediment above the central entrance, sidelight windows, and dual chimneys. Several other properties on the Town's Heritage Register are also identified as Georgian style, dating from the early to mid-nineteenth century. The architectural character of Glen Williams is defined by this style, with comparable examples at 504 and 510 Main Street (Figures 31 and 32), which share similarities in form, scale, materials, and design.



Figure 30: A Georgian Residence at 504 Main Street, Glen Williams. (Town of Halton Hills 2024)



Figure 31: A Georgian Residence at 510 Main Street, Glen Williams. (Google Street View 2023)

While the Frances H. Williams House at 15 Mountain Street has been modified with a modern Gothic Revival-style addition to the rear elevation, the building remains a representative example of a pre-Confederation Georgian home. Despite these alterations, it has preserved its architectural integrity and continues to stand in its original location for over 170 years at the southeast terminus of Mountain Street in Glen Williams.

3.0 Description of Heritage Attributes and Evaluation Checklist

The following evaluation checklist applies to Ontario Regulation 9/06 made under the *Ontario Heritage Act*: Criteria for Determining Cultural Heritage Value or Interest. The criteria are prescribed for municipal designation of Heritage Properties under Part IV, Section 29 of the *Ontario Heritage Act*. The evaluation tables utilize an 'X' to signify applicable criteria and 'N/A' to signify criteria that are not applicable for this property.

Design or Physical Value	
Is rare, unique, representative, or early example of a style, type, expression, material, or construction method	x
Displays a high degree of craftsmanship or artistic merit	x
Demonstrates a high degree of technical or scientific achievement	N/A

The property at 15 Mountain Street in Glen Williams is a representative example of mid-nineteenth century Georgian residential architecture. Key features characteristic of this style that are extant include the symmetrical front elevation, gable roof, graduated fenestration, Classical detailing, and dual chimneys at either end of the roof. The structure's brick construction is laid in a common bond pattern, and it features a raised stone foundation typical of residences in this style. Despite modifications over time, the building retains the defining elements of the Georgian style, illustrating the architectural preferences of the pre-Confederation era in Ontario.

The late 19th century addition to the rear is legible from the original Georgian building yet is compatible in terms of materials, detailing, and form. The addition, with its board and batten upper floor and stucco-covered ground-floor porch, reflects the architectural evolution of the property while maintaining visual continuity with the original structure.

Historical or Associative Value	
Has direct associations with a theme, event, belief, person, activity, organization, or institution that is significant to a community	x
Yields, or has potential to yield, information that contributes to an understanding of a community or culture	N/A
Demonstrates or reflects the work or ideas of an architect, artist, builder, designer, or theorist who is significant to a community	N/A

The property at 15 Mountain Street in Glen Williams is directly associated with the early European settlement of the area, and is associated in particular with the Williams family, a prominent pioneering family in the development of Glen Williams. Acquired by Benajah Williams in 1825, the property was part of the land where he established the village of Williamsburg (later Glen Williams) and developed vital milling industries that contributed to the community's growth. The existing Georgian home was constructed in 1854 by Benajah's son Charles Williams as a residence for Frances Huestis Williams, the widow of Jacob Williams. The property has also been associated with the Reid family, including Dugald Reid, a prominent Georgetown merchant, and his distant cousin William Henry Reid, a local stone mason. The Thompson family, who operated the Thompson & Wilson Beverage Company from the property, further contributed to the property's significance with its commercial use. These associations

with key figures and families in the development of Glen Williams emphasize the property's significance to the community.

Contextual Value	
Is important in defining, maintaining, or supporting the character of an area	x
Is physically, functionally, visually, or historically linked to its surroundings	x
Is a landmark	N/A

The property at 15 Mountain Street is physically, functionally, visually and historically linked to its surroundings in its original location on Mountain Street in the community of Glen Williams. The existing building is important in defining and maintaining the character of the area through its connection to other early Georgian residential dwellings in Glen Williams and to the Williams family, including the Williams-Holt House, Alexander House, original Glen Williams Schoolhouse, and the Williams House. The existing home is relative to the scale and setback of surrounding homes and has not been identified as a landmark.

4.0 Summary

Following research and evaluation according to Ontario Regulation 9/06, it has been determined that the property at 15 Mountain Street in Glen Williams has physical and design, historical and associative, and contextual value and therefore meets Ontario Regulation 9/06 criteria for determining cultural heritage value or interest.

The heritage attributes of the property at 15 Mountain Street are identified as follows:

- The setback, location, and orientation of the residential building along Mountain Street in Glen Williams;
- The scale, form, and massing of the c. 1854 two-storey Georgian-style residential building, including its shallow-pitched gable roof and twin chimneys;
- The materials, including brick laid in a common bond pattern, with a raised stone foundation;
- The front (northwest) elevation, including:
 - The original entrance location centered within the symmetrical façade at the first storey;
 - Extant rectangular window openings, including graduated fenestration;
 - Limestone sills and lintels on all window openings;
- The side (northeast) elevation, including:
 - Simple gable end featuring symmetrically placed, evenly spaced rectangular window openings;
 - Limestone sills and lintels on all extant window openings;
 - Brick chimney rising above the roofline of the gable end;
- The side (southwest) elevation, including:
 - Simple gable end featuring symmetrically placed, evenly spaced rectangular window openings;
 - Limestone sills and lintels on all extant window openings; and,
 - Brick chimney rising above the roofline of the gable end.

15 Mountain Street, Glen Williams | LT 39, RCP 1556; HALTON HILLS

The rear elevation and interiors have not been identified as heritage attributes of the property at 15 Mountain Street as part of this report.

5.0 Sources

Primary Sources

Archives and Government Records:

Archives of Ontario. Division Registrar Vital Statistics Records, 1858-1930. MS 940, reels 5-10, 16, 21, 26-27. Archives of Ontario, Toronto, Ontario, Canada.

Archives of Ontario. Registrations of Deaths, 1869-1942 (MS 935, reels 1-694). Archives of Ontario, Toronto, Ontario, Canada.

Archives of Ontario. Registrations of Ontario Overseas Deaths, 1939-1947. MS 944, reels 1-11. Archives of Ontario, Toronto, Ontario, Canada.

Esqueusing Township Voters List, Ward 6, 1908.

Library and Archives Canada. Voters Lists, Federal Elections, 1935-1980. R1003-6-3-E (RG113-B). Library and Archives Canada, Ottawa, Ontario, Canada.

Ontario Land Records. Lot 21, Concession 10.

U.S Patent Office, J.C.M Frost. Vertical Take Off and Landing Apparatus. May 1955.

Interview with Christine Earl. October 28, 2024. (Town of Halton Hills, 2024)

Newspapers:

“Bragg-Smith, Arthur.” Independent & Free Press (Georgetown, ON), January 22, 1997, p. 11, column 2.
[Bragg-Smith, Arthur \(Died\): Halton Hills Newspapers \(vitacollections.ca\)](https://www.vitacollections.ca/acton-free-press/1997-01-22-11-column-2-bragg-smith-arthur-died)

“Died: D. Reid.” Acton Free Press (Acton, ON), December 3, 1903, p. 2.
[Glenwilliams: Halton Hills Newspapers \(vitacollections.ca\)](https://www.vitacollections.ca/acton-free-press/1903-12-03-2-died-d-reid)

“Fenian Raid, June 2, 1866, Georgetown.” Georgetown Herald (Georgetown, ON), June 4, 1924, p. 1.
[Georgetown Herald \(Georgetown, ON\), June 4, 1924, p. 1: Halton Hills Newspapers \(vitacollections.ca\)](https://www.vitacollections.ca/georgetown-herald/1924-06-04-1-georgetown-herald-georgetown-on-june-4-1924-p-1)

“Fueling the Avian 2.” Georgetown Herald (Georgetown, ON), November 19, 1959, p. 9.
[https://vitacollections.ca/HaltonHillsNews/91500/page/9?q=Fueling+the+Avian&docid=OOI.91500](https://www.vitacollections.ca/halton-hills-news/1959-11-19-9-fueling-the-avian-2)

“George Reid was Early Georgetown Resident.” Georgetown Herald (Georgetown, ON), October 13, 1948, p. 12. [https://vitacollections.ca/HaltonHillsNews/90911/data](https://www.vitacollections.ca/halton-hills-news/1948-10-13-12-george-reid-was-early-georgetown-resident)

“Glen: Miss Thompson.” Georgetown Herald (Georgetown, ON), October 3, 1928, p. 2
[Georgetown Herald \(Georgetown, ON\), October 3, 1928: Halton Hills Newspapers \(vitacollections.ca\)](https://www.vitacollections.ca/georgetown-herald/1928-10-03-2-glen-miss-thompson)

“Glen Williams News.” Georgetown Herald (Georgetown, ON), April 18, 1923, p. 2.

"John A. Thompson Buried in Glen Cemetery." *Georgetown Herald* (Georgetown, ON), December 17, 1941, p. 1.

[Georgetown Herald \(Georgetown, ON\), December 17, 1941, p. 1: Halton Hills Newspapers \(vitacollections.ca\)](https://www.vitacollections.ca/Georgetown_Herald_(Georgetown,_ON),_December_17,_1941,_p._1:_Halton_Hills_Newspapers)

"Miss Mary Thompson was a Life Long Resident of Glen Williams." *Georgetown Herald* (Georgetown, ON), July 23, 1947, p. 1.

[Thompson, Mary Elizabeth: Halton Hills Newspapers \(vitacollections.ca\)](https://www.vitacollections.ca/Thompson,_Mary_Elizabeth:_Halton_Hills_Newspapers)

"Reids Hardware, Business Landmark changes ownership." *Georgetown Herald* (Georgetown, ON), August 22, 1945, p. 1.

[Georgetown Herald \(Georgetown, ON\), August 22, 1945, p. 1: Halton Hills Newspapers \(vitacollections.ca\)](https://www.vitacollections.ca/Georgetown_Herald_(Georgetown,_ON),_August_22,_1945,_p._1:_Halton_Hills_Newspapers)

Census Records:

England and Wales Civil Registration Indexes. London, England: General Register Office; United Kingdom; Volume: 9c; Page: 2624

Year: 1871; Census Place: Esquesing, Halton, Ontario; Roll: C-9956; Page: 39; Family No: 153.

Year: 1881; Census Place: Yorkville, York East, Ontario; Roll: C_13248; Page: 39; Family No: 195.

Year: 1891; Census Place: Esquesing, Halton, Ontario, Canada; Roll: T-6340; Family No: 88.

Year: 1891; Census Place: Esquesing, Halton, Ontario, Canada; Roll: T-6340; Family No: 114.

Glen Williams Public School Board. Summary of Attendance, 1918, 1923, 1924.

Secondary Sources

Charnov, Bruce H. *From Autogiro to Gyroplane*. Westpool, Con USA: Prager, 2003.

Dayfoot, Philo W., *Daybook*, Georgetown: 1850-1852

McDonald, John. *Halton Sketches Revisited*. Glen Williams, 1996.

"Private Flying - Canadian Gyroplane to be revived?". *Flight*, May 23, 1972, p. 760.

Rowe, J.M.B. *Bicentennial Directory of Glen Williams*. Glen Williams: 1984.

Rowe, J.M.B. *Charles Williams, The Miller*. Heritage Halton Hills, Georgetown: 2003.

Rowe, J.M.B. *Glen Williams: An Oasis in the Credit Valley*. Esquesing Historical Society, Georgetown: 2014.

Rowe, J.M.B. "Mountain Street Man Finds Refreshing Alternative to Prohibition." *Neighbours in the Glen*, 2017.

Rowe, J.M.B. *Bicentennial Directory of Glen Williams*. Glen Williams, 1984.

Find A Grave Index

15 Mountain Street, Glen Williams | LT 39, RCP 1556; HALTON HILLS

Wheeler, John A. Daybook. Glen Williams, 1890.

Warnock, Robert. A Sketch of Halton County: Canada West. Toronto: King Street Leader Steam Press, 1862.

Research and Evaluation Report



(Town of Halton Hills 2024)

Gibbons-Ross House

8 Albert Street, Georgetown, Town of Halton Hills

September 2024

Project Personnel

Report Authors

Caylee MacPherson
Planner – Development Review & Heritage

with

Laura Loney, MPlan, MCIP, CAHP, RPP
Manager of Heritage Planning

Historical Research

Caylee MacPherson

Field Review

Caylee MacPherson

Laura Loney

Report Preparation

Caylee MacPherson

Laura Loney

Mapping Graphics:

Rehan Waheed, MA
Planning Data Analyst

Report Reviewers:

Laura Loney

Bronwyn Parker
Director of Planning Policy

John Linhardt
Commissioner of Planning & Development

Austin Foster, MA
Cultural Heritage Assistant

Table of Contents

1.0. Property Description	5
2.0. Background	5
2.1 Historical Background	6
2.2 Property & Architectural Description.....	12
2.3 Architectural Style	15
3.0 Description of Heritage Attributes and Evaluation Checklist	16
4.0 Summary	17
5.0 Sources.....	18

Table of Figures

Figure 1: Location Map - 8 Albert Street.....	5
Figure 2: Aerial Photograph - 8 Albert Street.....	5
Figure 3: Subject property identified on the 1819 Patent Plan	7
Figure 4: Subject property identified on the 1822 Patent Plan	7
Figure 5: Subject property identified on Tremaine’s 1858 <i>Map of the County of Halton, Canada West</i>	7
Figure 6: Subject property identified on the 1859 Georgetown Plan of Town Lots.....	7
Figure 7: Subject property identified in the 1909 National Topographic Survey	8
Figure 8: Subject property identified on 1922 National Topographic Survey	8
Figure 9: Councillor Joseph Gibbons sitting alongside his fellow Council members, c. 1930 (EHS00899) ...	8
Figure 10: Mayor Joseph Gibbons standing alongside Council, c. 1965 (EHS8079).....	8
Figure 11: Subject property identified on the 1922 National Topographic Survey.....	9
Figure 12: Subject property identified on the 1934 Fire Insurance Plan	9
Figure 13: Glen Woollen Mills, c. 1915 (EHS292).....	9
Figure 14: Job Advertisement for Glen Textile Industries Ltd. (<i>Georgetown Herald</i> , August 12, 1942, p. 5)9	9
Figure 15: Subject property identified on the 1942 National Topographic Survey.....	10
Figure 16: Subject property identified on 1954 Town of Georgetown Survey.....	10
Figure 17: Subject property identified on 1954 aerial photography.....	10
Figure 18: Subject property identified on 1956 Town of Georgetown Survey.....	10
Figure 19: Subject property identified on 1965 aerial photography.....	11
Figure 20: Advertisement for Pearl Kerby of Dykstra Real Estate (<i>Georgetown Herald</i> , November 2, 1967, p. 11)	11
Figure 21: Subject property identified on 1974 National Topographic Survey	11
Figure 22: Subject property identified on 1985 aerial photography.....	11
Figure 23: Subject property identified on 1995 aerial photography.....	12
Figure 24: Subject property identified on 2007 aerial photography.....	12
Figure 25: Subject property identified on 2011 aerial photography.....	12
Figure 26: Subject property identified on 2017 aerial photography.....	12
Figure 27: Subject property identified on 2023 aerial photography.....	13
Figure 28: Looking south towards the existing dwelling from Albert Street (Town of Halton Hills 2024) ..	13

Figure 29: Looking east towards the existing dwelling (Town of Halton Hills 2024)..... 13
Figure 30: Obscured front (northwest) elevation of the existing dwelling (Town of Halton Hills 2024)..... 14
Figure 31: Obscured front (northwest) elevation of the existing dwelling (Town of Halton Hills 2024)..... 14
Figure 32: Unobscured front (southwest) elevation of the existing dwelling (HouseSigma 2021)..... 14
Figure 33: Existing covered wooden porch along the front (southwest) elevation (Town of Halton Hills 2024) 14
Figure 34: Side (northeast) elevation of the existing dwelling (Town of Halton Hills 2024) 15
Figure 35: Side (southwest) elevation of the existing dwelling (Town of Halton Hills 2024) 15

1.0. Property Description

8 Albert Street, Georgetown	
Municipality	Town of Halton Hills
County or Region	Regional Municipality of Halton
Legal Description	LT 72 SAS, PL 37; HALTON HILLS
Construction Date	c.1920s
Original Use	Residential
Current Use	Residential
Architect/Building/Designer	Constructed for John J. Gibbons
Architectural Style	Edwardian
Additions/Alterations	Rear Addition
Heritage Status	Listed on the Town’s Heritage Register
Recorder(s)	Caylee MacPherson with Laura Loney
Report Date	September 2024

2.0. Background

This research and evaluation report describes the history, context, and physical characteristics of the property at 8 Albert Street in Georgetown, Halton Hills, Ontario (Figure 1 and Figure 2). The report includes an evaluation of the property’s cultural heritage value as prescribed by the *Ontario Heritage Act*.

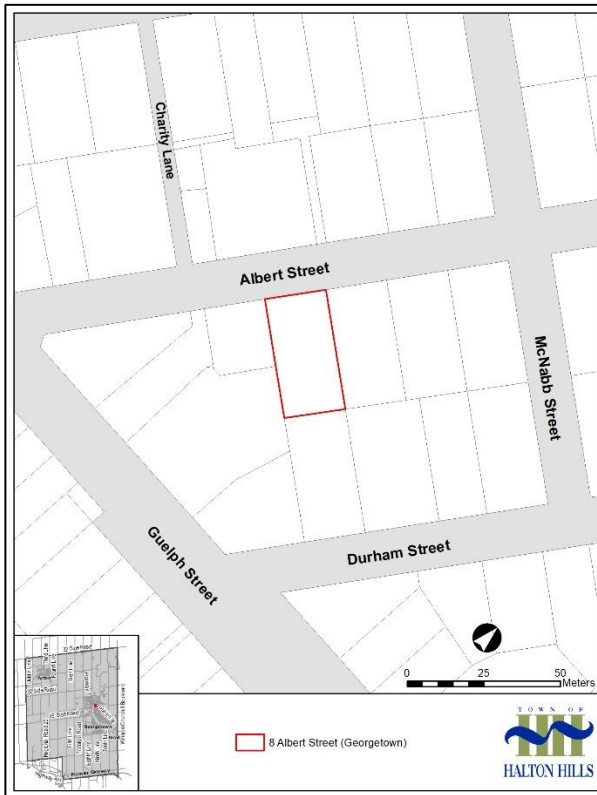

Figure 1: Location Map - 8 Albert Street



Figure 2: Aerial Photograph - 8 Albert Street

2.1 Historical Background

Indigenous History

The enduring history of First Nation Peoples in Halton Hills can be traced back through time immemorial before contact with Europeans in the 1600s. Prior to the arrival of European settlers, the Credit River was central to Indigenous ways of life, supporting settlements, fisheries, horticulture, transportation, and trade. Iroquoian-speaking peoples, ancestors of the Wendat, occupied the Credit River Valley for hundreds of years until the mid-1600s, establishing semi-permanent villages. There are numerous archaeological sites in Halton Hills dating from this period, ranging from village sites to burial grounds, which reveal a rich cultural heritage.

The Wendat were displaced by the Haudenosaunee around 1649-50 amid the conflicts that arose between European colonial powers and their First Nation allies. The Mississaugas (part of the Anishinaabe Nation) arrived in southern Ontario in the 1690s, settling in two groups along the north shore of Lake Ontario and Lake Erie. The western group, occupying the area between Toronto and Lake Erie, became known as the Mississaugas of the Credit First Nation. Until the early 19th century, the Mississaugas of the Credit First Nation followed a seasonal cycle of movement and resource harvesting along the Credit River (Missinnihe, meaning “trusting creek”), and other rivers. In the winter months, extended family groups hunted in the Halton Hills area, travelling south towards the mouth of the river in the spring for the salmon run. The Mississaugas’ fisheries and traditional economies were diminished because of increased Euro-colonial settlement, leading to a state of impoverishment and dramatic population decline.

In 1818, the British Crown negotiated the purchase of 648,000 acres of land from the Mississaugas of the Credit First Nation, including present-day Halton Hills, under the Ajetance Treaty (No. 19), named after Chief Ajetance. This left the Mississaugas with three small reserves on the Lake Ontario shoreline. The legitimacy of early land “surrenders” to the Crown is questionable when considering the Mississaugas’ traditional understanding of property ownership. Unlike the British, the Mississaugas understood land in spiritual terms, and did not share the idea that access to land and resources could be given up permanently

In 1986, the Mississaugas initiated a claim against the Government of Canada over the 1805 Toronto Purchase. On June 8, 2010, the parties involved reached a final compensatory agreement. It resulted in a cash payment of \$145 million to the Mississaugas of the Credit First Nation¹.

Early European History: Kennedy Family

Lot 18, Concession 9 was granted by the Crown to John Moore in 1821. In 1823, Moore sold the land to George Kennedy, who eventually surveyed the land into separate plots. An auction was held in 1852 to sell the building lots, and George Kennedy transferred the ownership to his nephew Jacob Kennedy.

¹ This brief overview of Pre-Treaty Indigenous Territory within the land now known as Halton Hills is taken from the Town of Halton Hills’ 2023 *Cultural Heritage Strategy*. This document includes additional recommendations relating to Truth and Reconciliation in Heritage Planning as part of the Town's commitment to advancing Truth and Reconciliation.



Figure 3: Subject property identified on the 1819 Patent Plan



Figure 4: Subject property identified on the 1822 Patent Plan

McKay Family

The subject property was transferred to Walter McKay (1822-1886) in 1872. McKay was employed as a carpenter from 1851 to 1875, following which he worked as an architect and builder. McKay was involved in the design and construction of many buildings in the Town of Halton Hills, including the Presbyterian Church in Norval, the former Presbyterian Church in Ballinafad, and the Georgetown Congregational Church along Church and Market Street.

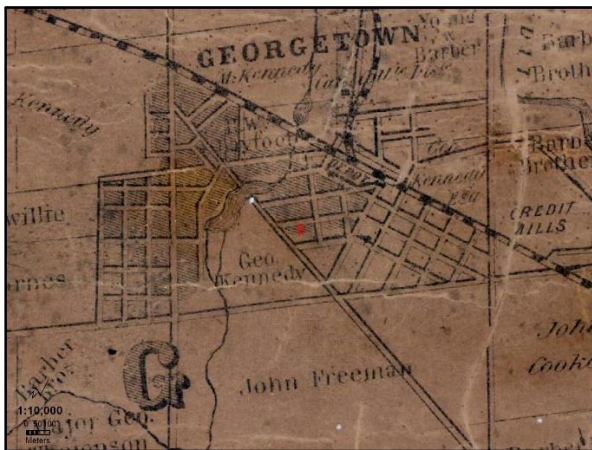

Figure 5: Subject property identified on Tremaine's 1858 Map of the County of Halton, Canada West

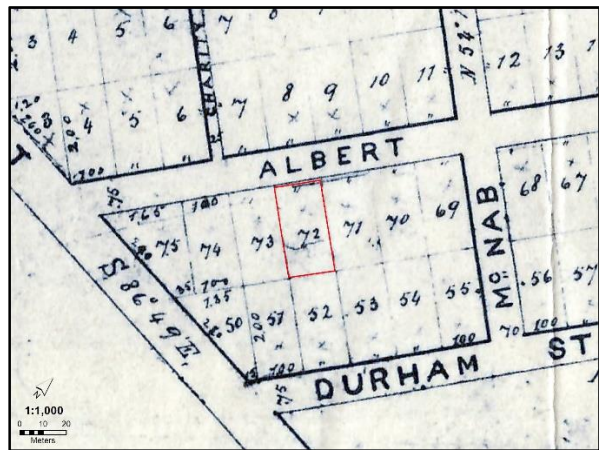

Figure 6: Subject property identified on the 1859 Georgetown Plan of Town Lots

In 1905, the subject property was transferred to Walter's son, Oliver McKay (1871-1931), who ran a local grocery store located on Mill Street before retiring in 1914. While living in Georgetown, Oliver was a member of Knox Presbyterian Church.

Joseph Gibbons

In 1919, Oliver McKay sold the property to John (Joseph) Gibbons (1890-1968) for \$250. While living in Georgetown, Gibbons was a well-known member of the community, originally moving to Georgetown in

1917 to open a barber shop with his business partner along Main Street. In later years, Gibbons operated a barber shop on his own before becoming involved in local politics in 1931.

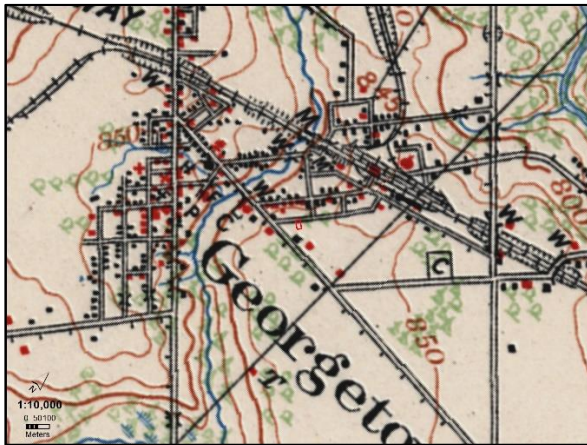

Figure 7: Subject property identified in the 1909 National Topographic Survey

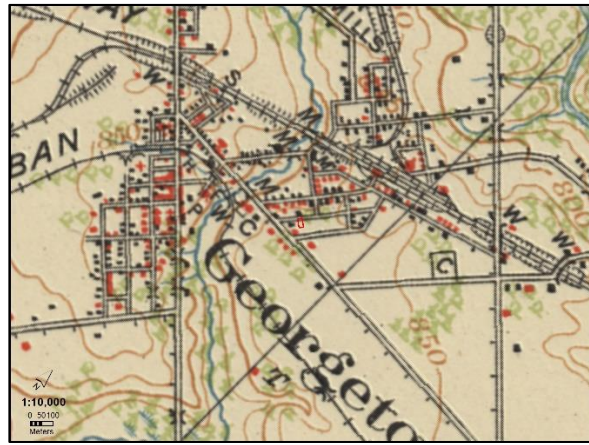

Figure 8: Subject property identified on 1922 National Topographic Survey

Gibbons was first elected as a councillor and held the position for three years before running for mayor. Following his election, Gibbons served a ten-year term from 1934-1943, and then took a break from politics for 2 years.

Following this leave, Gibbons was elected as a councillor and was elected mayor again between 1947-1949. In 1949, Gibbons was appointed as the Town's Assessment Commissioner, and later returned to politics, being re-elected as mayor once again from 1964-1968.



Figure 9: Councillor Joseph Gibbons sitting alongside his fellow Council members, c. 1930 (EHS00899)



Figure 10: Mayor Joseph Gibbons standing alongside Council, c. 1965 (EHS8079)

Gibbons served as a member of the Hydro Commission, the Board of Police Commissioners, and the Hospital Association. Outside of politics, Gibbons was a member of the Lions Club and Lawn Bowling Club.

Ross Family

By 1920, the property was sold to William James Ross (1857-1945) for \$1574, indicating that Joseph Gibbons likely constructed a house on the property. Ross was born in Toronto in 1857, and later moved to Maxwell to work at his family's woollen mill before commencing work as a railway switchman for the Canadian Pacific Railway. After receiving his pension, William and his wife Elizabeth (née Osborne) (1855-1936) moved to the extant dwelling. While residing in Georgetown, William became a member of the Knox Presbyterian Church and was known to be a Conservative in politics.

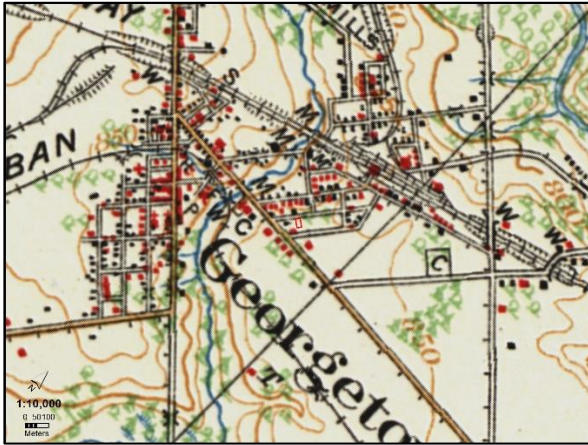

Figure 11: Subject property identified on the 1922 National Topographic Survey



Figure 12: Subject property identified on the 1934 Fire Insurance Plan

Glen Textiles Industries Ltd., and Hart Products Company of Canada

Following William Ross' death, the subject property was sold to Glen Textile Industries Limited ("Glen Textiles") in 1945. The Glen Textiles company was formerly located in the Barraclough Mills in Glen Williams and operated until the 1950s. During WWII, Glen Textiles supplied cloth and blankets for troops and civilians in Britain, France, Belgium, Norway, and Holland.



Figure 13: Glen Woollen Mills, c. 1915 (EHS292)



Figure 14: Job Advertisement for Glen Textile Industries Ltd. (*Georgetown Herald*, August 12, 1942, p. 5)

The first tenants to live in the house were Edgar Scott (1917-1978) and Antonia Scott (née Magioli) (1925-1996) in 1945, who later moved to 69 Guelph Street in 1947, directly across from Georgetown High School. Following the Scott family, James Linton (1913-1975) and Maxine Linton (1915-2000) moved into the extant dwelling in October 1947. The Linton's were originally from New Zealand, and arrived in Canada in May 1947, following which James worked as the manager of the Glen Textiles.



Figure 15: Subject property identified on the 1942 National Topographic Survey

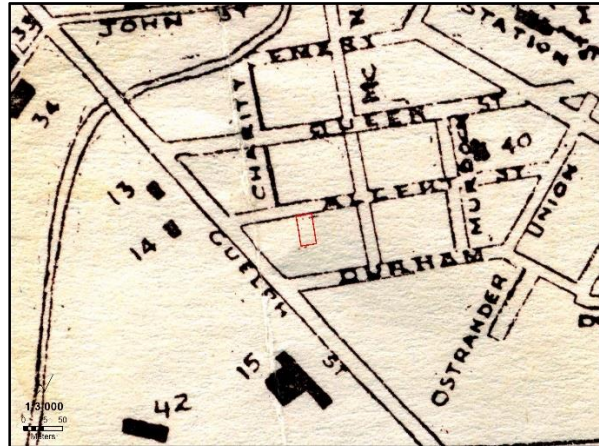

Figure 16: Subject property identified on 1954 Town of Georgetown Survey

Eventually, James Linton became involved with Knox Presbyterian Church and was added to the church's board of managers; James was also a member of the local Masonic Lodge. Maxine also became involved in the local community, participating as a member of the Imperial Order Daughters of the Empire (IODE) women's organization.



Figure 17: Subject property identified on 1954 aerial photography

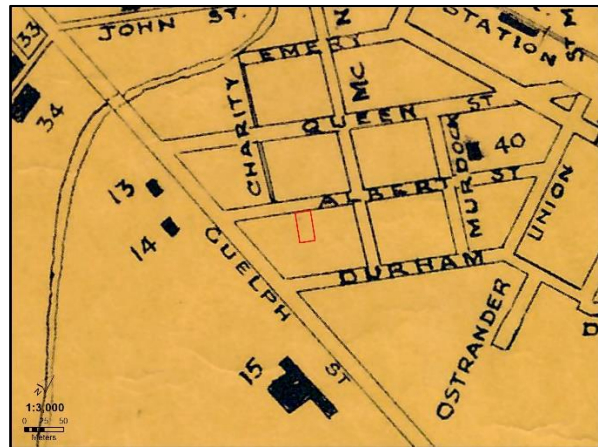

Figure 18: Subject property identified on 1956 Town of Georgetown Survey

In 1954, Hart Products Company of Canada purchased the property from Glen Textiles. During the same year, the Linton family purchased the property and continued to reside on Albert Street before selling the property to the Urquhart family in 1956 and moving to Lyons Court in Georgetown.

1960s - Present



Figure 19: Subject property identified on 1965 aerial photography

IMMACULATE
 6 ROOM BUNGALOW (clay brick) with all the trimmings. Allow yourself time to see it immediately, owner is moving away and it breaks his heart. This house is built by Mr. W. Pacholok in 1963 and has marvelous kitchen and dining area, good sized living room and three spacious bedrooms, professionally built recreation room with bar 20x25 and brick garage with paved driveway. Lot 50x150 (30 ft. hydro easement). 1st mortgage \$11,900 at 6 1/2%. Price \$21,900.

NEAR PERFECT
 THIS BUNGALOW is 8 years old and has 5 rooms, large kitchen, 11 1/2 x 15 and living room 13 1/2 x 19. You can just move in and place your furniture, that's how clean it is. Three nice bedrooms, basement with floor and walls painted, water-softener, garage, covered patio, paved driveway, very nice backyard, with several trees, and white birch and shrubs in front, owner also moving away due to circumstances. 1st mortgage \$9,300 at 6 1/4%. Price \$20,500.

DYKSTRA REAL ESTATE
 53 Delrex Blvd. North — 877-3245
 Representatives:
 PEARL KERBY: 877-3342 PHYLLIS MIERSMA: 877-9131

Figure 20: Advertisement for Pearl Kerby of Dykstra Real Estate (*Georgetown Herald*, November 2, 1967, p. 11)

Before living in Georgetown, Gordon (1899-1994) and Charlotte (1901-1975) Urquhart lived in Cornwall. The Urquhart family lived in the extant dwelling until 1974, when the property was purchased by Pearl Kerby (1929-2005), who worked as a real-estate agent in Georgetown.

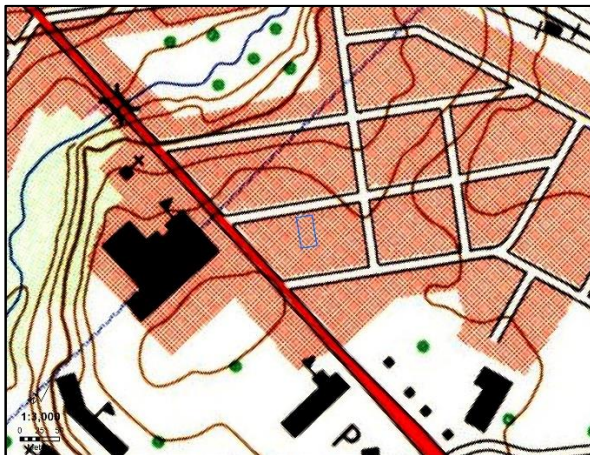

Figure 21: Subject property identified on 1974 National Topographic Survey



Figure 22: Subject property identified on 1985 aerial photography

Shortly after, the property was sold to Margaret Pratt in 1975. Pratt continued to live along Albert Street until 1978, when the property was purchased by Douglas Edward. In 1987, the property was sold to Walter Brooks and Patricia Firby who owned the dwelling until 2011, when they sold the property to Kerry Allen.



Figure 23: Subject property identified on 1995 aerial photography



Figure 24: Subject property identified on 2007 aerial photography

Allen oversaw ownership of the property for two years, before Bryan and Crystal Hoffman purchased the property in 2013. By 2016, the property was sold to Barbara Elvidge and Antonio Lee, who sold the property to its current owner in 2021.



Figure 25: Subject property identified on 2011 aerial photography

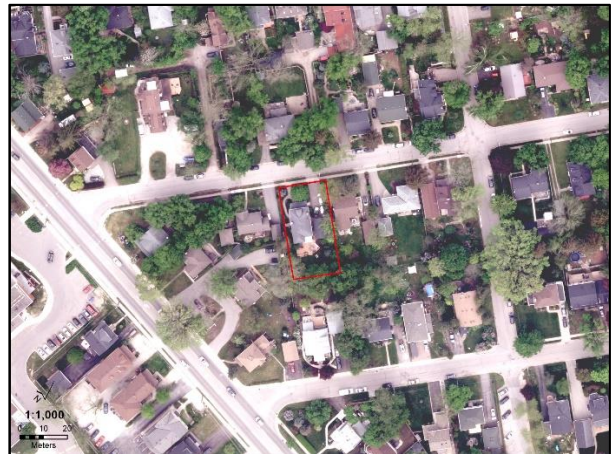

Figure 26: Subject property identified on 2017 aerial photography

2.2 Property & Architectural Description

The subject property is located along the southeast side of Albert Street in the community of Georgetown within the Town of Halton Hills. The property is a rectangular-shaped lot and features a two-storey red brick dwelling with a stone foundation, hipped roof, dormer, wooden covered porch, and an addition along the rear (southeast) elevation. The property can be accessed by vehicle via an asphalt driveway, located along the side (northeast), fronting onto Albert Street.

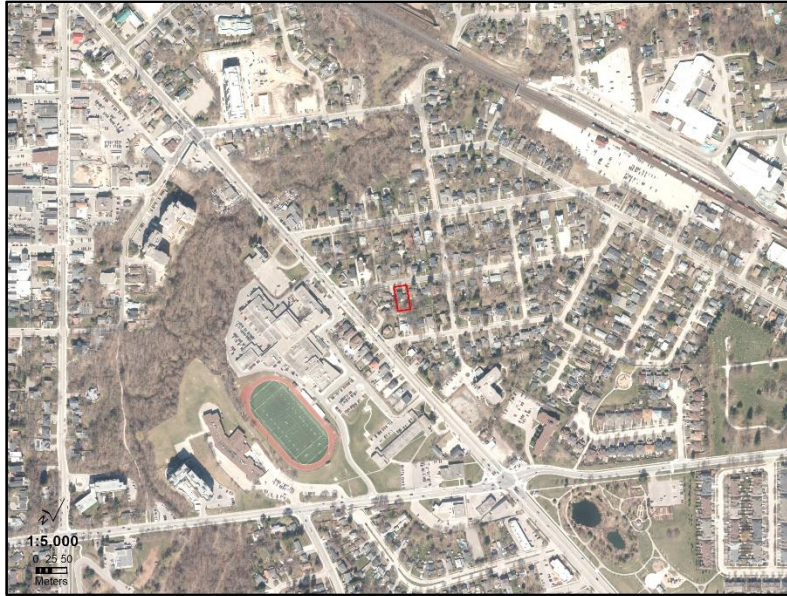

Figure 27: Subject property identified on 2023 aerial photography

The front (northwest) elevation features a one-storey covered wooden porch with white painted square half wooden columns and brick piers, plain eaves, and a contemporary metal railing. Along the first storey is an asymmetrical design, featuring a segmentally arched door opening with a brick voussoir, segmentally arched tripartite window opening with a brick voussoir and stone sill, as well as a smaller square window opening with a segmental arch, brick voussoir and stone sill. Surrounding the windows are contemporary vinyl window shutters.



Figure 28: Looking south towards the existing dwelling from Albert Street (Town of Halton Hills 2024)



Figure 29: Looking east towards the existing dwelling (Town of Halton Hills 2024)



Figure 30: Obscured front (northwest) elevation of the existing dwelling (Town of Halton Hills 2024)

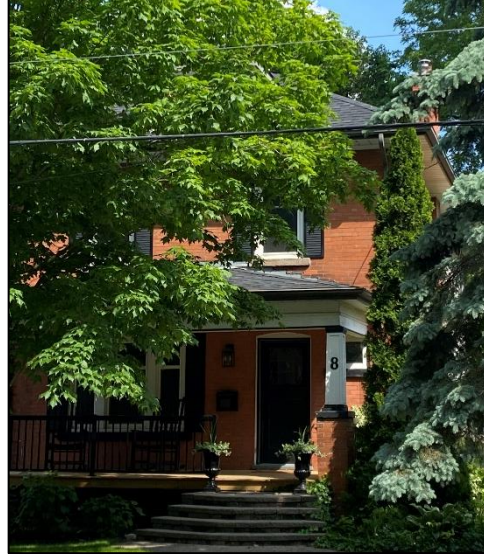

Figure 31: Obscured front (northwest) elevation of the existing dwelling (Town of Halton Hills 2024)

At the second storey are two symmetrically placed, segmentally arched window openings, with radiating brick voussoirs and stone sills. Above the roofline is a dormer with a hipped roof, grey vinyl cladding, and a flatheaded window opening. Like the first storey, both window openings are encased by black vinyl window shutters.



Figure 32: Unobscured front (southwest) elevation of the existing dwelling (HouseSigma 2021)



Figure 33: Existing covered wooden porch along the front (southwest) elevation (Town of Halton Hills 2024)

The side (northeast) elevation along the first storey features a brick chimney that extends above the roofline, and a twin segmentally arched window opening with a brick voussoir and stone sill. On the second storey are two differently sized segmentally arched window openings with brick voussoirs and stone sills.



Figure 34: Side (northeast) elevation of the existing dwelling (Town of Halton Hills 2024)



Figure 35: Side (southwest) elevation of the existing dwelling (Town of Halton Hills 2024)

On the alternate side (southwest) elevation is segmentally arched entrance with a brick voussoir, segmentally arched window openings with brick voussoirs and stone sills, and a chimney extending from the first storey above the roofline. Like the other side (northeast) elevation, the second storey features two differently sized segmentally arched window openings with brick voussoirs and stone sills.

Towards the rear of the property is a contemporary two-storey addition clad with vinyl siding. The addition features multiple flatheaded window openings on both side (northeast and southwest) elevations.

2.3 Architectural Style

The Edwardian style, or Edwardian Classicism, emerged during the 20th century and was a more simplified and humble style compared to the more intricate architectural styles found throughout the late-nineteenth century. The Edwardian style provided an alternative to contemporary Period and Colonial Revivals, which were often influenced by Victorian architecture.

Shannon Kyles of *Ontario Architecture* notes that Edwardian Classicism style buildings typically feature modest and balanced facades, and featured details such as, but not limited to:

- Gabled or hipped roof shapes;
- Dormers included on the front and/or side elevations;
- Three to four bedrooms on the upper storey (American Four-Square layout);
- Front porch containing white painted wood, as well as clustered or half columns; and,
- Smooth brick facades and tall brick chimneys.

The extant dwelling at 8 Albert Street features smooth red brick cladding with tall chimneys extending beyond the roofline on both side (southwest and northeast) elevations, a central dormer along the front

(northwest) elevation, a one-storey wooden covered porch with white painted half columns atop brick bases, and an American Four-Square layout typical to Edwardian style dwellings.

3.0 Description of Heritage Attributes and Evaluation Checklist

The following evaluation checklist applies to Ontario Regulation 9/06 made under the *Ontario Heritage Act*: Criteria for Determining Cultural Heritage Value or Interest. The criteria are prescribed for municipal designation of Heritage Properties under Part IV, Section 29 of the *Ontario Heritage Act*. The evaluation tables utilize an 'X' to signify applicable criteria and 'N/A' to signify criteria that are not applicable for this property.

Design or Physical Value	
Is rare, unique, representative, or early example of a style, type, expression, material, or construction method	X
Displays a high degree of craftsmanship or artistic merit	N/A
Demonstrates a high degree of technical or scientific achievement	N/A

The property at 8 Albert Street has physical and design value as it is a representative example of an early twentieth-century residential building in the Edwardian architectural style. The two-storey residential building features a hipped roof, central dormer along the front elevation, smooth red brick façade and tall brick chimney, an American Four-Square layout, as well as a covered porch with white painted half wood columns with brick bases, which are elements and characteristics typical to the Edwardian style.

Historical or Associative Value	
Has direct associations with a theme, event, belief, person, activity, organization, or institution that is significant to a community	X
Yields, or has potential to yield, information that contributes to an understanding of a community or culture	N/A
Demonstrates or reflects the work or ideas of an architect, artist, builder, designer, or theorist who is significant to a community	N/A

The property has historical and associative value, due to its associations John Joseph Gibbons. Gibbons was a local business owner, and long-term politician in Georgetown, serving as a Councillor from 1931-1934, before being elected as mayor for three terms from 1934-1943, 1947-1949, and 1964-1968. Gibbons also served as a member of the Hydro Commission, the Board of Police Commissioners, and the Hospital Association, along with having membership with the Lions Club and Lawn Bowling Club. The property also has associations with the William James Ross, who worked as a railway switchman for the Canadian Pacific Railway and was a member of the local Knox Presbyterian Church.

The property is also associated with Glen Textiles Industries Ltd., a textile company formerly located in the Barraclough Mills in Glen Williams during the mid-nineteenth century. During WWII, Glen Textiles played a key role in the war effort and was a supplier of cloth and blankets for troops and civilians in Britain, France, Belgium, Norway, and Holland.

The property also has historical and associative value due to its associations with the development of Albert Street following the construction of the Grand Trunk Railway Station. During this time, the surrounding area experienced significant residential development and growth.

Contextual Value	
Is important in defining, maintaining, or supporting the character of an area	X
Is physically and functionally, visually, or historically linked to its surroundings	X
Is a landmark	N/A

The property at 8 Albert Street has contextual value as it is important in defining and maintaining the late-nineteenth and early twentieth-century character of Albert Street, surrounding the former Grand Trunk Railway Station in Georgetown. The property remains physically, visually, and historically linked to its surroundings as a residential building along Albert Street. The property is relative in scale and design to neighbouring properties and has not been identified as a landmark in the community

4.0 Summary

Following research and evaluation according to Ontario Regulation 9/06, it has been determined that the property at 8 Albert Street has physical and design, historical and associative, and contextual value and therefore meets Ontario Regulation 9/06 criteria for determining cultural heritage value or interest.

The heritage attributes of the property at 8 Albert Street are identified as follows:

- The setback, location, and orientation of the existing building along Albert Street in Georgetown;
- The scale, form, and massing of the existing c.1920s, two-storey Edwardian residential building with hipped roof, brick chimneys, and stone foundation;
- The materials, including smooth red brick, wood, and stone;
- The front (northwest) elevation, including:
 - o The covered wooden porch with square half wooden columns and plain eave detailing, brick podiums;
 - o Segmentally arched window openings with brick voussoirs and stone sills at the first and second storey;
 - o Dormer located at the second storey with hipped roof and flatheaded window opening; and,
- The side (southwest and northwest) elevations, including:
 - o Segmentally arched window openings with brick voussoirs and stone sills at the first and second storey.

The rear addition and interiors have not been identified as heritage attributes as part of this report.

5.0 Sources

Primary Sources

Ancestry.com. *Canada, Find a Grave® Index, 1600s-Current* [database on-line]. Lehi, UT, USA: Ancestry.com Operations, Inc., 2012.

Ancestry.com. 1891 Census of Canada [database on-line]. Lehi, UT, USA: Ancestry.com Operations Inc, 2023.

Ancestry.com. 1901 Census of Canada [database on-line]. Lehi, UT, USA: Ancestry.com Operations Inc, 2023.

Ancestry.com. 1911 Census of Canada [database on-line]. Lehi, UT, USA: Ancestry.com Operations Inc, 2023.

Ancestry.com. 1921 Census of Canada [database on-line]. Lehi, UT, USA: Ancestry.com Operations Inc, 2023.

Ancestry.com. 1931 Census of Canada [database on-line]. Lehi, UT, USA: Ancestry.com Operations Inc, 2023.

Ontario Land Records, ONLand

Acton Free Press

“Scott, Edgar Charles”. (November 15, 1978). *Acton Free Press* (Acton, ON), p. 22.
<https://news.haltonhills.halinet.on.ca/2314130/page/22?q=edgar&docid=OOI.2314130>

Georgetown Herald

Dykstra Real Estate Advertisement. (November 2, 1967). *Georgetown Herald* (Georgetown, ON), p. 11. <https://vitacollections.ca/HaltonNews/91923/page/11?n=>

“Many Improvements Made at Knox Church” (February 11, 1953). *Georgetown Herald* (Georgetown, ON), p. 10.
<https://vitacollections.ca/HaltonHillsNews/page.asp?ID=91138&po=10&q=%22James+Linton%22&docid=OOI.91138>

“Mayor’s Death Ends 36 Year Municipal Career”. (November 28, 1968). *Georgetown Herald* (Georgetown, ON), p. 1.
<https://news.halinet.on.ca/91980/page/1?q=%22Joseph+Gibbons%22&docid=OOI.91980>

“New Zealander Speaks to I.O.D.E of Homeland”. (November 14, 1951). *Georgetown Herald* (Georgetown, ON), p. 1.
<https://vitacollections.ca/HaltonHillsNews/page.asp?ID=91072&po=1&q=%22James+Linton%22&docid=OOI.91072>

War Work Advertisement. (August 12, 1942). *Georgetown Herald* (Georgetown, ON), p. 5.
<https://vitacollections.ca/HaltonImages/90585/page/5?n=>

“We See This Week.” (October 22, 1947). *Georgetown Herald* (Georgetown, ON), p. 1.
<https://news.haltonhills.halinet.on.ca/90853/page/1?q=%22Glen+Textiles%22+%22Linton%22&docid=OOI.90853>

“William James Ross Dies in 88th Year”. (January 10, 1945). *Georgetown Herald* (Georgetown, ON), p. 1.
<https://news.haltonhills.halinet.on.ca/90710/page/1?q=%22William+James+Ross%22&docid=OOI.90710>

Secondary Sources

Benbow Rowe, John Mark (2006). *Georgetown: Reflections of a Small Town*.

Benbow Rowe, John Mark (2014). *Glen Williams: An Oasis in the Credit Valley. Esquesing Historical Society: Georgetown*.

Biographical Dictionary of Architects in Canada, 1800-1950. *McKay, Walter*.
<http://dictionaryofarchitectsincanada.org/node/2216>

Blumenson, J. (1990). *Ontario Architecture: A Guide to Styles and Building Terms 1784 to the present*. Canada: Fitzhenry & Whiteside

Glen Woollen Mills (1915). Esquesing Historical Society. (EHS292).

HouseSigma (2021). *8 Albert Street, Halton Hills*. Retrieved from: https://housesigma.com/on/halton-hills-real-estate/8-albert-st/home/r56k97wJk8RyKRjD?id_listing=jAXw7Qw1EZdYQOzg

Kyles, S. Edwardian (1890-1916). Accessed July 2024

Mayor Alongside Council (1965). Esquesing Historical Society. (EHS8079).

Town Council (1930). Esquesing Historical Society. (EHS00899)